

# SHEAVES

Roll-forged sheaves that provide an upset metal flow without creating a stress zone at the splitting point.



## CROSBY VALUE ADDED

**McKissick® Roll-Forged Heavy Duty Sheaves** are made by upsetting and forming the groove and flange walls in multiple steps, eliminating the need to split and weaken the groove. This exclusive forging process adds extra strength to the critical groove section.

**McKissick Domed Reinforced Extreme Duty Roll Forged Sheaves** are welded in a circular pattern thus eliminating the higher stresses created by welding ribs or other forms of stiffeners.

**McKissick Heavy Duty Sheaves** are available with machined groove rings or machine forged rings utilized for the rim or hub.

**McKissick Heavy Duty Closed-Die Forged Sheaves** offer the performance of closed-die forging with the precision machining capabilities of CNC machinery.

**McKissick Normal Duty Malleable Cast Sheaves** provide economical solutions for normal service applications.

**McKissick Sheaves** come in a variety of sizes to suit your specific applications. Crosby offers many sheaves as standard and these are shown in the pages that follow. For applications that require unique specifications, Crosby can make minor modifications to many of the sheaves listed at a reasonable charge. We can also custom design and manufacture sheaves to your exact requirements. McKissick roll forged sheaves can be furnished balanced or with lightening holes at a reasonable charge on request.

**Crosby's hardening technique** is a science. It provides a precise maximum hardness for wear-resistance across the wire rope contact area. The McKissick sheave groove is flame hardened to a minimum 35 Rockwell C for a 140° contact area with the wire rope (upon special request the McKissick sheave groove can be flame hardened to a minimum 50 Rockwell C for a 150° contact area with the wire rope). The solid steel plate provides the ideal surface for flame hardening and a closer tolerance fit to the wire rope to reduce fatigue and wear.

The **McKissick hub** is stepped to eliminate stress failure in the weld, common in traditional hub designs. The hub is pressed into place with complete metal-to-metal contact. This helps ensure an accurate alignment to the hub's axis so there is no wobble or lopping of the rotating sheave. The precision aligned hub / sheave wheel combination adds to the bearing life and keeps the sheave on the job longer.

## McKISSICK® STANDARD BEARINGS

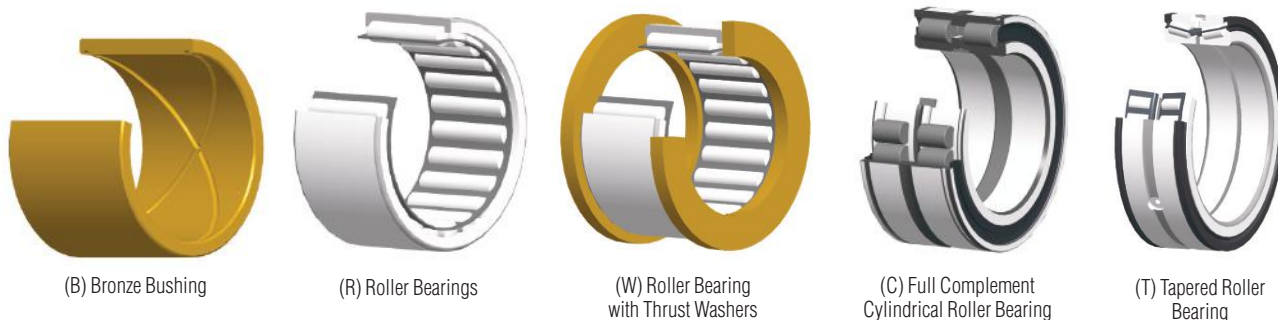

## ORDERING INSTRUCTIONS

The following information should be specified when ordering blocks and sheaves:

### Blocks

- Wire rope diameter
- Sheave OD
- Shaft or bore size
- Bearing type or plain bore
- Hub width
- Rim width
- Stock number (if known)
- Special machine features
- Special finishes

If hub or rim dimensions necessitate a dimension other than those shown in this catalog, please contact The Crosby Group for minimums and maximums. Tapered roller bearing sheaves show width over bearing cones, which cannot be altered.

Price and delivery for your special needs, if not shown, are available upon request.

McKissick® Sheaves Bearings Application Information

BRONZE BUSHING

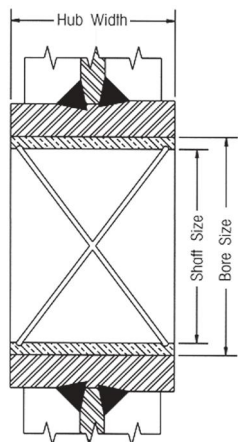

Slow line speed, moderate load and moderate use

- Maximum Bearing Pressure (BP): 31N/mm<sup>2</sup>
- Maximum Velocity at Bearing (BV): 366m/min
- Maximum Pressure Velocity Factor (PV): 114

$$\text{Formula for BP} = \frac{\text{Line Pull} \times \text{Angle Factor}}{\text{Shaft Size} \times \text{Hub Width}}$$

For underwater sheave applications, special bronze bushings are available. Consult the bearing manufacturer for applicable load.

Example

Using a 14in sheave (917191) with a 4,600 lb line pull and an 80 degree angle between lines, determine maximum allowable line speed:

$$\text{BP} = \frac{\text{Line Pull} \times \text{Angle Factor}}{\text{Shaft Size} \times \text{Hub Width}} = \frac{4,600 \text{ lbs} \times 1.53}{1.50 \times 1.62} = 2,896 \text{ PSI}$$

$$\text{BV} = \frac{\text{PV Factor}}{\text{BP}} = \frac{55,000}{896} = 19 \text{ FPM}$$

ROLLER BEARINGS

Bronze Bushings with Fig. 8 oil grooves are made from SAE 660 bronze for cold-finished shafts.

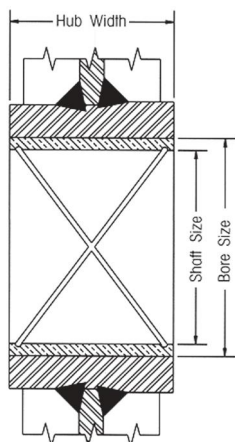

Roller Bearings are designed to operate on shafts carburized to 60 Rockwell C and grounded to +/- .0005 of shaft size.

STANDARD STRAIGHT ROLLER BEARINGS

Heavier loads, higher speeds, more frequent use, radial loads only.

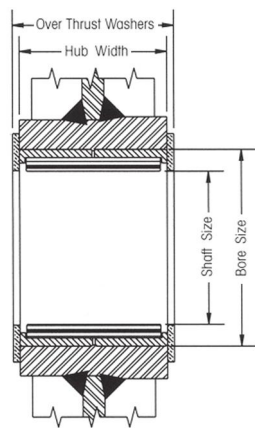

Roller Bearings without inner races are designed to operate on shafts carburized to 60 Rockwell C and grounded to +/- .0005 of shaft size.

FULL COMPLEMENT, DOUBLE ROW, ROLLER BEARING

Heavy load, high speeds, continuous operation, axial, and radial loads.

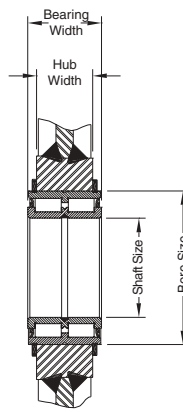

Cylindrical Roller Bearings with snap ring grooves are complete units with outer and inner rings, rib-guided cylindrical rollers, and sealing rings. They can support axial forces in both directions, as well as radial forces. They have high dynamic and static load ratings.

TAPERED ROLLER BEARINGS

Heavy loads, high speeds, continuous operation, axial, and radial loads.

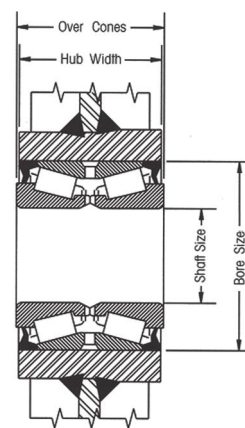

Tapered Bearings are designed to operate on shafts machined to +/- .0005 of shaft size. Applications should provide for tightening separator plates against bearing cones to adjust and insure proper function of bearings.

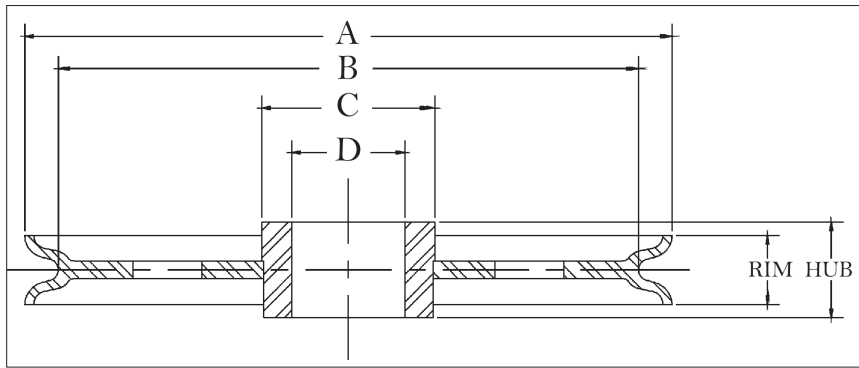

APPLICATION AND WARNING INFORMATION  
SECTION 17

**McKissick® Plain Bore Sheaves**

- Roll-Forged™ sheaves are available in sizes up to 78” in diameter.
- McKissick® Plain Bore Sheaves can be equipped with bushings or bearings at an optional charge.
- 14” diameter sheaves and larger are Roll-Forged with flame hardened grooves to minimum Rockwell 35C, unless otherwise noted.

“A” Nominal Outside Diameter (in)	Stock Number	Wire Rope Diameter (in)	“D” Bore Size (in)	Hub Width (in)	Rim Width (in)	“C” Nominal Hub Outside Diameter (in)	“B” Nominal Tread Diameter (in)	Material	Approx. Weight (lb)
3.00	51008	1/4	0.752	1.310	1.25	1.12	2.06	B.S.	1.0
3.00	11310	3/8	0.752	1.310	1.25	1.12	2.06	B.S.	1.0
4.00	51044	1/4	1.569	1.000	0.88	2.00	3.12	B.S.	2.0
4.00	1189	3/8	1.569	1.000	0.88	2.00	3.12	B.S.	2.0
4.88	2026409	5/8	1.749	1.250	1.12	2.25	4.06	F.S.	3.6
5.88	2023136	3/4	1.875	1.750	1.62	2.50	4.38	F.S.	6.0
6.00	51124	3/8	1.625	1.125	1.00	2.25	4.94	F.S.	4.0
6.00	13014	1/2	1.625	1.125	1.00	2.25	4.94	F.S.	4.0
7.00	51437	1/4	1.875	1.375	0.75	2.38	6.25	B.S.	6.2
7.00	3203	3/8	1.875	1.375	0.75	2.38	6.25	B.S.	6.2
8.00	61710	1/2	1.848	1.313	1.25	2.44	6.62	F.S.	8.0
8.00	2023144	1/2	1.875	1.750	1.62	2.56	6.31	F.S.	10.0
8.00	51598	5/8	1.875	1.500	1.38	2.44	6.62	F.S.	7.0
8.00	2023146	5/8	1.875	1.750	1.62	2.56	6.31	F.S.	10.0
8.00	5194	3/4	1.875	1.500	1.38	2.44	6.62	F.S.	7.0
8.00	2023152	3/4	1.875	1.750	1.62	2.56	6.31	F.S.	10.0
8.00	2023466	1	2.750	2.500	2.38	4.00	5.25	F.S.	15.0
8.50	61747	3/8	1.848	1.313	1.00	2.75	7.50	D.I.	11.0
9.88	51918	3/8	3.000	1.750	1.12	3.75	8.56	F.S.	14.0
9.88	2023154	1/2	1.875	1.750	1.62	2.56	8.31	F.S.	14.5
9.88	6040	1/2	3.000	1.750	1.12	3.75	8.56	B.S.	14.0
9.88	5675	5/8	1.375	1.500	1.38	3.25	8.50	F.S.	9.5
9.88	2023169	5/8	1.875	1.750	1.62	2.56	8.31	F.S.	14.5
9.88	2023173	3/4	1.875	1.750	1.62	2.56	8.31	F.S.	14.5
9.88	2023419	7/8	2.500	2.313	2.18	3.50	8.12	F.S.	15.0
10.00	2023784	1-1/8	4.000	2.500	2.38	5.75	7.38	F.S.	27.0
12.00	2023247	5/8	1.875	1.750	1.62	3.25	10.12	F.S.	18.0
12.00	2023234	3/4	1.875	1.750	1.62	3.25	9.75	F.S.	18.0
12.00	52285	3/4	3.000	1.750	1.62	4.50	9.75	R.F.	16.0
12.00	2026537	3/4	3.000	2.313	2.18	4.50	9.75	R.F.	24.0
12.00	62283	7/8	3.000	2.188	2.18	4.50	10.25	R.F.	24.0
12.00	2030845	1	2.500	2.313	2.31	4.00	9.38	R.F.	24.0
13.00	33653	3/8	2.500	1.500	1.12	3.50	11.62	R.F.	14.0
13.00	50704	1/2	2.500	1.500	1.12	3.50	11.62	R.F.	14.0
14.00	*52720	1/2	4.250	2.500	1.38	5.06	12.62	D.I.	15.0
14.00	2023249	5/8	1.875	1.750	1.62	3.25	12.12	R.F.	20.0
14.00	4013098	5/8	2.500	1.750	1.62	4.50	12.12	R.F.	31.0
14.00	4013187	5/8	2.375	1.750	1.62	4.50	12.12	R.F.	30.0
14.00	4013105	3/4	2.500	1.750	1.62	4.50	11.75	R.F.	31.0
14.00	4016503	3/4	3.250	2.313	2.18	5.50	11.75	R.F.	34.0
14.00	2023564	1-1/8	2.750	2.500	2.38	4.50	11.38	R.F.	28.0
16.00	4010046	3/4	4.250	2.750	2.50	5.75	13.38	R.F.	45.0
16.00	4010126	1	4.250	2.750	2.50	5.75	13.38	R.F.	42.0
18.00	4010493	7/8	3.500	2.313	2.38	5.50	14.94	R.F.	64.0
20.00	*4014024	5/16	4.250	2.750	1.38	5.75	18.88	R.F.	45.0
20.00	4010616	3/4	3.500	2.313	2.18	5.50	18.00	R.F.	66.0
20.00	4010885	3/4	4.250	2.750	2.12	6.50	18.00	R.F.	80.0
20.00	4013613	1	3.750	2.313	2.18	5.50	16.50	R.F.	76.0
20.00	4010625	7/8	3.500	2.313	2.18	5.50	16.94	R.F.	74.0



Custom sheaves are available.

# McKissick® Plain Bore Sheaves

"A" Nominal Outside Diameter (in)	Stock Number	Wire Rope Diameter (in)	"D" Bore Size (in)	Hub Width (in)	Rim Width (in)	"C" Nominal Hub Outside Diameter (in)	"B" Nominal Tread Diameter (in)	Material	Approx. Weight (lb)
20.00	4010901	1	4.250	2.750	2.12	6.50	16.50	R.F.	80.0
24.00	4012749	9/16	6.500	3.375	3.12	8.00	22.00	R.F.	148
24.00	*4014408	5/8	4.722	2.750	1.50	6.50	21.75	R.F.	120
24.00	4011385	1	3.000	2.500	2.38	4.50	21.12	R.F.	125
24.00	4012785	1	6.100	2.875	2.62	8.00	21.12	R.F.	130
24.00	4011223	1-1/8	4.500	3.000	2.75	6.50	20.06	R.F.	130
24.00	2029333	1-1/8	6.500	3.375	3.12	8.00	20.06	R.F.	132
24.00	4011410	1-1/2	6.500	3.375	3.12	8.25	20.00	R.F.	186
30.00	2026302	7/8	6.500	3.375	3.12	8.00	27.00	R.F.	187
30.00	2029382	1/1/4	7.875	3.500	3.12	9.50	26.38	R.F.	225
36.00	4012160	1-1/8	6.500	3.375	3.12	8.25	32.25	R.F.	341
36.00	4012730	1-1/2	7.875	3.500	3.25	9.50	32.00	R.F.	302
42.00	4015844	1-1/8	8.875	3.625	3.25	11.00	38.50	R.F.	460
42.00	4015853	1-1/4	8.875	3.625	3.25	11.00	38.38	R.F.	460
42.00	4015719	1-1/4	10.875	3.625	3.38	12.50	38.38	R.F.	443
42.00	4015719	1-1/4	10.875	3.625	3.38	12.50	38.38	R.F.	443

\*Without flame hardening.

 Custom sheaves are available.

## VIDEO PODCAST SERIES

Our experts answer some of your most common safe rigging, lifting, and securement questions in our video podcast series, *Ask the Expert*.

Watch four episodes on sheaves:

- Bronze bushing vs roller bushing
- Understanding groove hardness
- How to know when it's time to replace sheaves
- How to extend the life of a sheave

## Ask the Expert

VIDEO PODCAST

[thecrosbygroup.com/podcast-sheaves](http://thecrosbygroup.com/podcast-sheaves)

Be sure to subscribe to The Crosby Group's YouTube channel to catch every new video as soon as it's released.

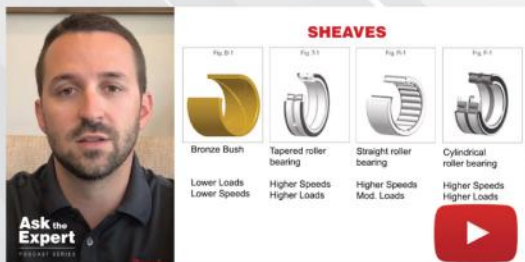

**SHEAVES**

Fig. B-1: Bronze Bush  
Lower Loads  
Lower Speeds

Fig. B-2: Tapered roller bearing  
Higher Speeds  
Higher Loads

Fig. B-3: Straight roller bearing  
Higher Speeds  
Mod. Loads

Fig. B-4: Cylindrical roller bearing  
Higher Speeds  
Higher Loads

Ep. 27 Sheaves: bronze bushing vs roller bushing

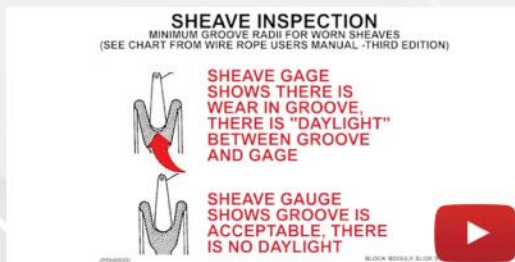

**SHEAVE INSPECTION**  
MINIMUM GROOVE RADII FOR WORN SHEAVES  
(SEE CHART FROM WIRE ROPE USERS MANUAL - THIRD EDITION)

SHEAVE GAGE SHOWS THERE IS WEAR IN GROOVE, THERE IS "DAYLIGHT" BETWEEN GROOVE AND GAGE

SHEAVE GAGE SHOWS GROOVE IS ACCEPTABLE, THERE IS NO DAYLIGHT

Ep. 32 How to know when it's time to replace sheaves



Min 35Rc for higher hardness in the bottom of the groove - extending the lifetime of the sheave and rope.

Ep. 30 Understanding sheave groove hardness

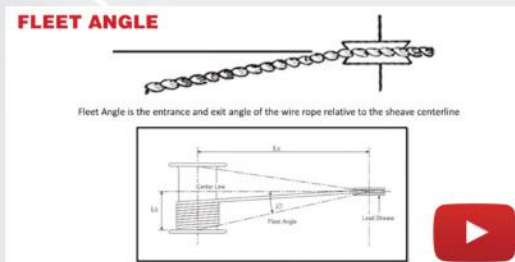

**FLEET ANGLE**

Fleet Angle is the entrance and exit angle of the wire rope relative to the sheave centerline

Ep. 34 How to extend the life of a sheave

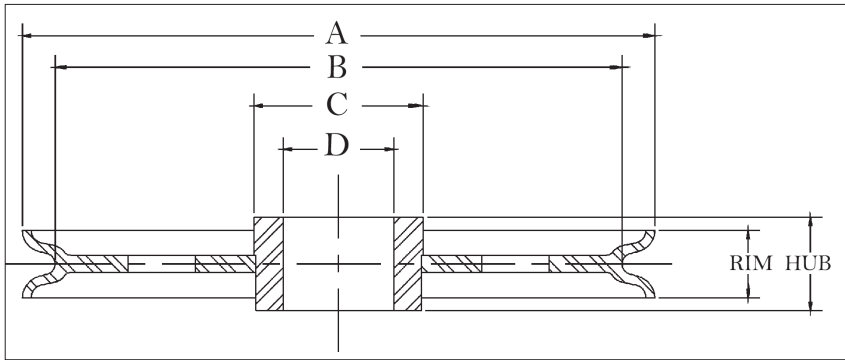

APPLICATION AND WARNING INFORMATION  
SECTION 17

### McKissick® Common Bore Sheaves

- Roll-Forged sheaves are available in sizes up to 78" in diameter.
- Common Bore or Plain Bore are terms used when there is merely a hole bored in the center of the sheave.
- Common Bore Sheaves are machined for a running fit for the shaft size listed, and no bearing or bushing is installed.

"A" Nominal Outside Diameter (in)	Stock Number	Wire Rope Diameter (in)	"D" Shaft Size (in)	Hub Width (in)	Rim Width (in)	"C" Nominal Hub Outside Diameter (in)	"B" Nominal Tread Diameter (in)	Material	Approx. Weight (lb)
3	905051	3/16	0.375	0.781	0.75	1.00	2.38	P.M.	1.0
3	905079	3/16	0.500	0.781	0.75	1.00	2.38	P.M.	1.0
3	905097	3/16	0.625	0.781	0.75	1.00	2.38	P.M.	1.0
3	905024	1/4	0.375	0.500	0.50	1.00	2.62	P.M.	0.8
3	905042	1/4	0.500	0.500	0.50	1.00	2.62	P.M.	0.8
4	905122	5/16	0.500	0.750	0.62	1.38	3.50	P.M.	1.0
4	905140	5/16	0.625	0.750	0.62	1.38	3.50	P.M.	1.0
4	905168	3/8	0.500	0.812	0.75	1.50	3.25	P.M.	1.3
4	905202	3/8	0.750	0.812	0.75	1.50	3.25	P.M.	1.3
4	905220	1/2	0.500	1.062	1.00	1.62	3.18	P.M.	1.5
4	905248	1/2	0.625	1.062	1.00	1.62	3.18	P.M.	1.5
5	905293	3/16	0.750	0.938	0.88	2.25	4.25	P.M.	2.3
5	905300	3/8	0.750	0.938	0.88	2.25	4.25	P.M.	2.3
5	905328	1/2	0.625	1.062	1.00	2.25	4.00	P.M.	2.5
6	905426	3/8	0.500	0.812	0.75	1.88	5.00	D.I.	2.5
6	905480	3/8	0.500	1.062	1.00	1.88	5.00	D.I.	2.5
6	905462	3/8	0.750	0.812	0.75	1.88	5.00	P.M.	2.5
6	905523	3/8	0.750	1.062	1.00	18.80	5.00	P.M.	4.2
6.75	905701	3/8	0.750	1.188	1.12	2.00	5.88	D.I.	5.0
8	905747	1/2	0.750	1.125	1.00	2.38	6.88	D.I.	5.0
8	905783	1/2	1.000	1.125	1.00	2.38	6.88	D.I.	8.5
8	905809	5/8	0.750	1.375	1.25	2.00	6.50	D.I.	6.0
8	905845	5/8	1.000	1.375	1.25	2.00	6.50	D.I.	6.8
8	909324	5/8	1.000	1.375	1.25	2.50	6.62	D.I.	8.5
8	909342	5/8	1.125	1.375	1.25	2.50	6.62	D.I.	8.5
8	909360	5/8	1.250	1.375	1.25	2.50	6.62	D.I.	8.5
8	909388	5/8	1.500	1.375	1.25	2.50	6.62	D.I.	8.5
10	905943	1/2	1.000	1.125	1.00	2.88	8.75	D.I.	10.0
10	906005	5/8	1.000	1.375	1.25	3.00	8.50	D.I.	9.3
10	909761	5/8	1.500	1.375	1.25	3.00	8.50	D.I.	13.5
12	906041	1/2	1.000	1.125	1.00	4.00	10.62	D.I.	16.5
12	906087	1/2	1.250	1.125	1.00	4.00	10.62	D.I.	16.5
12	906247	7/8	1.500	2.000	1.75	3.75	10.00	D.I.	20.3
14	*906283	3/4	1.125	1.625	1.50	3.25	12.25	C.I.	26.5
14	*906309	3/4	1.250	1.625	1.50	3.25	12.25	C.I.	26.5
18	910820	1	2.000	2.000	1.88	4.00	14.88	R.F.	62.0

Material: B.S.=Bar Steel, C.I.=Cast Iron, F.S.=Forged Steel, D.I.=Ductile Iron, C.S.=Cast Steel, P.M.=Powdered Metal, R.F.=Roll-Forged.

\*Without flame hardening groove.



Custom sheaves are available.

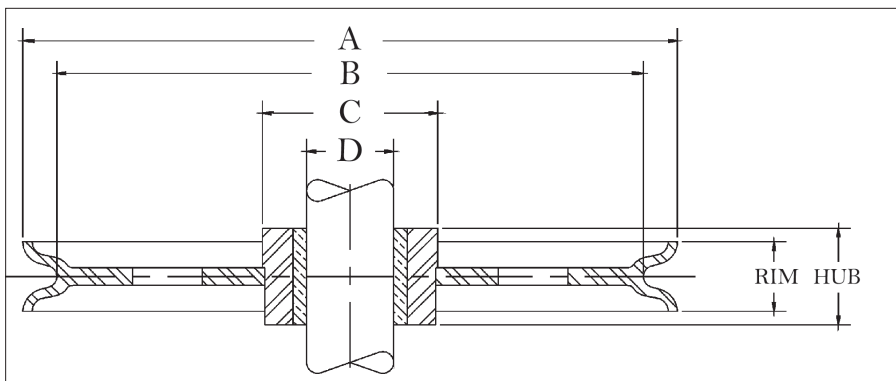

APPLICATION AND WARNING INFORMATION  
SECTION 17

### McKissick® Bronze Bushed Sheaves

- Roll-Forged sheaves are available in sizes up to 78" in diameter.
- McKissick® Bronze Bushed Sheaves are equipped with S.A.E. 660 Bronze Bushings for cold finished shafts with "Figure 8" oil groove, or self-lubricating Bronze as designated by an asterisk (\*) next to the shaft size.
- For sizes not listed, McKissick® Finished Bore Sheaves can be equipped with bronze bushings at an optional charge.
- Bronze Bushed Sheaves are designed to operate on shafts machined to +.000/- .002 in of the indicated shaft size.

"A" Nominal Outside Diameter (in)	Stock Number	Wire Rope Diameter (in)	"D" Shaft Size (in)	Hub Width (in)	Rim Width (in)	"C" Nominal Hub Outside Diameter (in)	"B" Nominal Tread Diameter (in)	Material	Approx. Weight (lb)
2.25	907004	1/4	0.375	0.625	0.56	0.75	1.88	B.S.	0.8
3.00	907077	3/16	0.500	0.781	0.75	1.00	2.38	P.M.	1.0
3.00	907095	3/16	0.625	0.781	0.75	1.00	2.38	P.M.	1.0
3.00	907022	1/4	0.375	0.500	0.50	1.00	2.62	P.M.	0.8
3.00	907040	1/4	0.500	0.500	0.50	1.00	2.62	P.M.	0.8
3.00	907086	3/8	0.500	0.750	0.75	1.00	2.38	P.M.	1.0
3.00	916110	3/8	0.500	0.781	0.75	1.50	2.38	B.S.	1.0
3.00	460156	3/8	0.500	1.313	1.18	1.12	2.06	B.S.	1.0
3.00	907102	3/8	0.625	0.750	0.75	1.00	2.38	P.M.	1.0
3.00	2030895	3/8	0.750	1.000	0.88	1.75	2.25	P.M.	1.5
4.00	460290	1/8	1.000	1.000	0.88	2.00	3.12	B.S.	2.0
4.00	907111	3/16	0.500	0.750	0.62	1.38	3.50	P.M.	1.0
4.00	907139	3/16	0.625	0.750	0.62	1.38	3.50	P.M.	1.0
4.00	916147	1/4	0.500	0.812	0.75	2.00	3.25	B.S.	1.5
4.00	916165	1/4	0.750	0.812	0.75	2.00	3.25	B.S.	1.5
4.00	460307	1/4	1.000	1.000	0.88	2.00	3.12	B.S.	2.0
4.00	907120	5/16	0.500	0.750	0.62	1.38	3.50	P.M.	1.0
4.00	907148	5/16	0.625	0.750	0.62	1.38	3.50	P.M.	1.0
4.00	907166	3/8	0.500	0.812	0.75	1.50	3.25	P.M.	1.3
4.00	916156	3/8	0.500	0.812	0.75	2.00	3.25	B.S.	1.5
4.00	907184	3/8	0.625	0.812	0.75	1.50	3.25	P.M.	1.4
4.00	907200	3/8	0.750	0.812	0.75	1.50	3.25	P.M.	1.3
4.00	460316	3/8	1.000	1.000	0.88	2.00	3.12	B.S.	2.0
4.00	907228	1/2	0.500	1.062	1.00	1.62	3.18	P.M.	1.5
4.00	907246	1/2	0.625	1.062	1.00	1.62	3.18	P.M.	1.5
4.00	907264	1/2	0.750	1.062	1.00	1.62	3.18	P.M.	1.5
4.12	2023186	3/8	1.000	1.500	1.38	2.00	3.00	F.S.	3.5
4.12	2023188	5/8	1.000	1.500	1.38	2.00	3.00	F.S.	3.5
4.25	460441	1/2	0.625	1.188	0.94	2.12	3.38	B.S.	2.4
4.88	460478	3/8	1.250	1.250	1.12	2.25	4.06	F.S.	3.6
4.88	460469	5/8	1.250	1.250	1.12	2.25	4.06	F.S.	3.6
5.00	907273	3/16	0.625	0.938	0.88	2.25	4.25	P.M.	2.3
5.00	460511	5/16	0.750	1.000	0.88	1.50	4.00	F.S.	2.5
5.00	907282	3/8	0.625	0.938	0.88	2.25	4.25	P.M.	2.8
5.00	907308	3/8	0.750	0.938	0.88	2.25	4.25	P.M.	2.8
5.00	460520	3/8	0.750	1.000	0.88	1.50	4.00	F.S.	2.5
5.00	907344	1/2	0.750	1.062	1.00	2.25	4.00	P.M.	2.5
5.25	460637	3/4	1.000	1.500	1.38	2.06	3.88	F.S.	4.0
5.88	2023129	5/8	1.500	1.750	1.62	2.50	4.38	F.S.	6.0
5.88	2023137	3/4	1.500	1.750	1.62	2.50	4.38	F.S.	6.0
6.00	907424	3/8	0.500	0.812	0.75	1.88	5.00	P.M.	2.5
6.00	907488	3/8	0.500	1.062	1.00	1.88	5.00	P.M.	2.5
6.00	907442	3/8	0.625	0.812	0.75	1.88	5.00	P.M.	2.5
6.00	907503	3/8	0.625	1.062	1.00	1.88	5.00	P.M.	2.5
6.00	907460	3/8	0.750	0.812	0.75	1.88	5.00	P.M.	2.5
6.00	907521	3/8	0.750	1.062	1.00	1.88	5.00	P.M.	4.3
6.00	2026483	3/8	0.750	1.062	1.00	2.00	5.12	F.S.	4.0

Custom sheaves are available.

# McKissick® Bronze Bushed Sheaves

"A" Nominal Outside Diameter (in)	Stock Number	Wire Rope Diameter (in)	"D" Shaft Size (in)	Hub Width (in)	Rim Width (in)	"C" Nominal Hub Outside Diameter (in)	"B" Nominal Tread Diameter (in)	Material	Approx. Weight (lb)
6.00	916245	3/8	0.875	1.062	1.00	2.00	5.12	F.S.	4.0
6.00	2028641	3/8	1.000	1.062	1.00	2.00	5.12	F.S.	4.0
6.00	460682	3/8	1.250	1.125	1.00	2.25	4.94	F.S.	3.7
6.00	907549	1/2	0.625	1.188	1.12	1.88	4.88	P.M.	5.0
6.00	907567	1/2	0.750	1.188	1.12	1.88	4.88	P.M.	4.7
6.00	913024	1/2	0.875	1.062	1.00	1.88	4.88	P.M.	3.8
6.00	460879	1/2	1.000	1.500	1.25	3.12	4.75	B.S.	7.0
6.00	460673	1/2	1.250	1.125	1.00	2.25	4.94	F.S.	3.6
6.00	2028048	1/2	1.000	1.062	1.00	1.88	4.88	P.M.	3.8
6.00	2026938	5/8	0.750	1.062	1.00	2.00	5.12	F.S.	4.0
6.00	913060	5/8	0.750	1.313	1.25	1.88	4.75	P.M.	3.8
6.00	913088	5/8	0.875	1.313	1.25	1.88	4.75	P.M.	5.0
6.00	2026822	5/8	1.000	1.062	1.00	2.00	5.12	F.S.	4.0
6.00	913104	5/8	1.000	1.313	1.25	1.88	4.75	P.M.	3.8
6.00	2023264	5/8	2.000	2.313	2.19	3.12	4.25	F.S.	9.5
6.00	460897	3/4	1.000	1.500	1.25	3.50	4.75	B.S.	7.0
6.00	913168	3/4	1.000	1.562	1.50	1.88	4.62	P.M.	6.8
6.00	2023260	3/4	2.000	2.313	2.19	3.12	4.25	F.S.	9.5
6.00	2023262	7/8	2.000	2.313	2.19	3.50	4.25	F.S.	9.5
6.75	907692	1/4	0.750	1.188	1.12	2.00	5.88	D.I.	5.0
6.75	907718	1/4	1.000	1.188	1.12	2.00	5.88	D.I.	5.0
6.75	907709	3/8	0.750	1.188	1.12	2.00	5.88	D.I.	5.0
6.75	907727	3/8	1.000	1.188	1.12	2.00	5.88	D.I.	5.0
7.00	461020	1/4	1.500	1.375	0.75	2.38	6.25	B.S.	6.2
7.00	461039	3/8	1.500	1.375	0.75	2.38	6.25	B.S.	6.2
7.00	907629	1/2	0.750	1.062	1.00	2.00	5.62	D.I.	4.3
7.50	460986	5/8	1.000	1.500	1.38	2.06	6.31	F.S.	7.5
7.50	460977	3/4	1.000	1.500	1.38	2.06	6.31	F.S.	7.5
7.62	461262	3/8	1.000	1.500	1.25	2.38	6.18	D.I.	7.0
7.62	461280	1/2	1.000	1.500	1.25	2.38	6.18	D.I.	7.0
7.62	461271	5/8	1.000	1.500	1.25	2.38	6.18	D.I.	7.0
8.00	907745	1/2	0.750	1.125	1.00	2.38	6.88	D.I.	5.0
8.00	916487	1/2	0.750	1.375	1.25	2.00	6.62	F.S.	7.0
8.00	907763	1/2	0.875	1.125	1.00	2.38	6.88	D.I.	5.0
8.00	907781	1/2	1.000	1.125	1.00	2.38	6.88	D.I.	5.6
8.00	916520	1/2	1.000	1.375	1.25	2.00	6.62	F.S.	7.0
8.00	2026841	1/2	1.125	1.375	1.25	2.00	6.62	F.S.	7.0
8.00	2026844	1/2	1.250	1.375	1.25	2.00	6.62	F.S.	7.0
8.00	461235	1/2	1.500	1.500	1.38	2.44	6.62	F.S.	7.0
8.00	2023145	1/2	1.500	1.750	1.62	2.56	6.31	F.S.	10.0
8.00	907807	5/8	0.750	1.375	1.25	2.00	6.50	D.I.	6.8
8.00	913300	5/8	0.875	1.375	1.25	2.50	6.62	D.I.	8.5
8.00	913328	5/8	1.000	1.375	1.25	2.75	6.62	D.I.	7.2
8.00	913364	5/8	1.250	1.375	1.25	2.50	6.62	D.I.	8.5
8.00	913382	5/8	1.500	1.375	1.25	2.50	6.62	D.I.	8.5
8.00	461244	5/8	1.500	1.500	1.38	2.44	6.62	F.S.	7.0
8.00	2023147	5/8	1.500	1.750	1.62	2.56	6.31	F.S.	10.0
8.00	461253	3/4	1.500	1.500	1.38	2.44	6.00	F.S.	7.0
8.00	2023153	3/4	1.500	1.750	1.62	2.56	6.31	F.S.	10.0
8.00	2028227	3/4	2.000	2.313	2.12	3.25	6.12	F.S.	12.5
8.00	461397	3/4	2.750	2.313	2.18	3.75	6.00	B.S.	10.5
8.00	2023386	7/8	2.000	2.313	2.12	3.25	6.12	F.S.	12.5
8.00	2023467	1	2.250	2.500	2.38	4.50	5.38	F.S.	18.0
8.00	2023463	1-1/8	2.250	2.500	2.38	4.50	5.38	F.S.	18.0
9.88	462831	3/8	2.500	1.750	1.12	3.75	8.56	F.S.	14.0
9.88	462154	1/2	1.000	1.500	1.38	3.25	8.50	F.S.	9.5
9.88	2023166	1/2	1.500	1.750	1.62	2.56	8.31	F.S.	14.5
9.88	462840	1/2	2.500	1.750	1.12	3.75	8.56	F.S.	14.0
9.88	2023170	5/8	1.500	1.750	1.62	2.56	8.31	F.S.	14.5
9.88	2023174	3/4	1.500	1.750	1.62	2.56	8.31	F.S.	14.5
9.88	2023420	7/8	2.000	2.313	2.18	3.50	8.12	F.S.	15.0
9.88	2023428	1	2.000	2.313	2.18	3.50	8.12	F.S.	15.0
10.00	907923	1/2	0.875	1.125	1.00	2.88	8.75	D.I.	10.0
10.00	907941	1/2	1.000	1.125	1.00	2.88	8.75	D.I.	11.8
10.00	907969	5/8	0.750	1.375	1.25	2.00	8.50	D.I.	9.3
10.00	908003	5/8	1.000	1.375	1.25	2.00	8.50	D.I.	9.3
10.00	916726	5/8	1.000	1.375	1.25	2.75	8.50	F.S.	14.0
10.00	2027291	5/8	1.250	1.375	1.25	2.75	8.50	F.S.	14.0
10.00	913765	5/8	1.500	1.375	1.25	3.00	8.50	D.I.	12.6
10.00	913863	3/4	1.500	1.625	1.50	3.50	8.25	F.S.	16.0



Custom sheaves are available.



# McKissick® Bronze Bushed Sheaves

"A" Nominal Outside Diameter (in)	Stock Number	Wire Rope Diameter (in)	"D" Shaft Size (in)	Hub Width (in)	Rim Width (in)	"C" Nominal Hub Outside Diameter (in)	"B" Nominal Tread Diameter (in)	Material	Approx. Weight (lb)
10.00	913845	3/4	1.250	1.625	1.50	3.50	8.25	F.S.	16.0
10.00	916833	3/4	1.500	1.625	1.50	3.25	7.75	F.S.	17.0
10.00	913807	3/4	1.000	1.625	1.50	3.50	8.25	F.S.	16.0
10.00	2026861	1-1/8	2.250	2.500	2.38	4.50	7.38	F.S.	27.0
10.00	2023785	1-1/8	3.500	2.500	2.38	5.75	7.38	F.S.	28.0
11.88	462323	3/8	2.500	2.313	1.00	3.75	10.75	D.I.	11.2
12.00	908049	1/2	1.000	1.125	1.00	4.00	10.62	D.I.	16.5
12.00	908085	1/2	1.250	1.125	1.00	4.00	10.62	D.I.	16.5
12.00	917011	5/8	1.125	1.625	1.50	3.25	10.12	F.S.	18.0
12.00	2023227	5/8	1.500	1.750	1.62	3.25	10.25	F.S.	22.0
12.00	462387	5/8	2.000	2.313	2.18	4.50	10.12	R.F.	26.0
12.00	462564	5/8	2.500	1.750	1.62	4.50	10.12	R.F.	24.0
12.00	908129	3/4	1.000	1.625	1.50	2.75	10.25	D.I.	18.3
12.00	914149	3/4	1.250	1.625	1.50	5.25	10.25	D.I.	25.5
12.00	914167	3/4	1.500	1.625	1.50	5.25	10.25	D.I.	25.5
12.00	2023235	3/4	1.500	1.750	1.62	3.25	9.38	F.S.	22.0
12.00	462449	3/4	2.000	2.313	2.18	4.50	9.75	R.F.	26.0
12.00	346593	3/4	2.250	2.313	2.18	4.50	9.75	R.F.	26.0
12.00	462573	3/4	2.500	1.750	1.62	4.50	9.38	R.F.	24.0
12.00	4104882	3/4	2.500	1.750	1.62	4.50	9.75	R.F.	25.0
12.00	4104917	3/4	2.500	2.313	2.18	4.50	9.75	R.F.	25.0
12.00	462485	3/4	3.000	3.000	1.88	5.50	9.38	R.F.	21.0
12.00	908245	7/8	1.500	2.000	1.75	3.75	10.00	D.I.	20.3
12.00	462458	7/8	2.000	2.313	2.18	4.50	10.25	R.F.	26.0
12.00	2023554	7/8	2.250	2.500	2.38	4.50	9.38	R.F.	28.0
12.00	4104891	7/8	2.500	1.750	1.62	4.50	10.25	R.F.	25.0
12.00	462467	1	2.000	2.313	2.18	4.00	10.00	R.F.	26.0
13.00	462779	3/8	2.000	1.500	1.12	3.50	11.62	R.F.	14.0
13.00	462788	1/2	2.000	1.500	1.12	3.50	11.62	R.F.	14.0
14.00	**463518	1/2	3.750	2.500	1.38	5.06	12.62	R.F.	15.0
14.00	463625	5/8	1.500	1.750	1.62	3.25	12.12	R.F.	20.0
14.00	4103552	5/8	2.000	1.750	1.62	4.50	12.12	R.F.	29.2
14.00	**908281	3/4	1.125	1.625	1.44	3.25	12.25	C.I.	26.5
14.00	**908307	3/4	1.250	1.625	1.50	3.25	12.25	C.I.	26.5
14.00	917173	3/4	1.250	1.625	1.50	4.00	12.00	R.F.	26.5
14.00	917191	3/4	1.500	1.625	1.50	3.25	11.75	R.F.	26.5
14.00	463634	3/4	1.500	1.750	1.62	3.25	11.38	R.F.	20.0
14.00	4103632	3/4	2.000	1.750	1.62	4.50	11.75	R.F.	30.0
14.00	4104828	3/4	2.750	2.313	2.18	5.50	11.75	R.F.	35.0
14.00	4103641	7/8	2.000	1.750	1.62	4.50	12.25	R.F.	31.0
14.00	463466	1-1/8	2.250	2.500	2.38	4.50	11.38	R.F.	28.0
16.00	4101395	1/2	3.500	2.750	2.50	5.75	14.25	R.F.	54.0
16.00	4100047	3/4	3.500	2.750	2.50	5.75	13.38	R.F.	47.0
16.00	4100109	3/4	3.750	2.750	2.50	5.75	13.38	R.F.	42.0
16.00	4103703	7/8	2.500	2.313	2.18	4.50	12.94	R.F.	35.0
16.00	4105211	7/8	2.750	2.313	2.18	4.50	12.94	R.F.	42.0
16.00	917360	1	2.000	2.000	1.75	4.25	13.25	R.F.	34.0
16.00	4100127	1	3.750	2.750	2.50	5.75	13.25	R.F.	63.0
18.00	4105131	7/8	3.000	2.313	2.18	5.50	14.94	R.F.	52.0
18.00	917486	1	2.000	2.000	1.88	4.50	14.88	R.F.	55.0
18.00	4104052	1	2.750	2.313	2.18	5.50	14.88	R.F.	66.0
18.00	4105140	1	3.000	2.313	2.18	5.50	14.88	R.F.	52.0
20.00	4100341	3/4	3.000	2.313	2.18	5.50	18.00	R.F.	68.0
20.00	4105239	3/4	3.750	2.750	2.12	6.50	18.00	R.F.	68.0
20.00	4100350	7/8	3.000	2.313	2.18	5.50	17.12	R.F.	45.0
20.00	4100369	1	3.000	2.313	2.18	5.50	17.12	R.F.	80.2
20.00	4105257	1	3.750	2.750	2.12	6.50	16.50	R.F.	68.0
20.00	4105275	1	5.500	2.875	2.62	8.00	17.12	R.F.	68.0
24.00	4105355	7/8	5.750	3.380	3.12	8.00	21.00	R.F.	133
24.00	4105382	1	5.500	2.875	2.62	8.00	21.12	R.F.	130
24.00	4100868	1-1/8	4.000	3.000	2.75	6.50	20.06	R.F.	110
24.00	4105391	1-1/8	5.500	2.875	2.62	8.00	20.06	R.F.	134
24.00	4105373	1-1/8	5.750	3.750	3.12	8.00	20.06	R.F.	137
30.00	4105426	7/8	5.750	3.380	3.12	8.00	27.00	R.F.	203
30.00	4105435	1	5.750	3.375	3.12	8.00	27.00	R.F.	203
30.00	4105444	1-1/8	5.750	3.375	3.12	8.00	27.00	R.F.	203
30.00	4105462	1-1/8	7.000	3.500	3.12	9.50	26.38	R.F.	211
30.00	4105471	1-1/4	7.000	3.500	3.12	9.50	26.38	R.F.	211

\*\* Without Flame Harden groove.

Material: B.S.=Bar Steel, C.I.=Cast Iron, F.S.=Forged Steel, D.I.=Ductile Iron, C.S.=Cast Steel, P.M.=Powdered Metal, R.F.=Roll-Forged.



Custom sheaves are available.

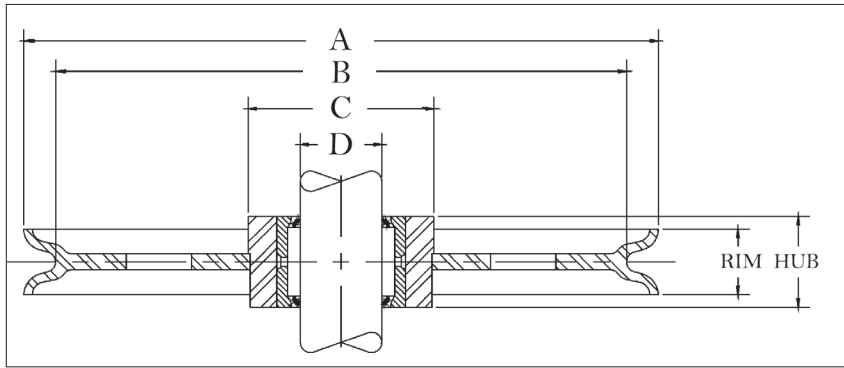

APPLICATION AND WARNING INFORMATION  
SECTION 17

### McKissick® Roller Bearing Sheaves

- Roll-Forged sheaves are available in sizes up to 78” in diameter.
- McKissick® Roller Bearing Sheaves are designed to operate on shafts carburized to 60 Rockwell C and grind to -.003/-.004 of the indicated shaft size. Some sizes are available with an optional inner race. Check with Crosby Sales for prices and correct shaft size.
- Application should provide for 1/32” running clearance over the hub width.
- For sizes not listed, McKissick® Finished Bore Sheaves can be equipped with Roller Bearings at an optional charge.

“A” Nominal Outside Diameter (in)	Stock Number	Wire Rope Diameter (in)	“D” Shaft Size (in)	Hub Width (in)	Rim Width (in)	“C” Nominal Hub Outside Diameter (in)	“B” Nominal Tread Diameter (in)	Material	Approx. Weight (lb)
4.00	472508	1/8	1.000	1.000	0.88	2.00	3.12	B.S.	2.0
4.00	472517	1/4	1.000	1.000	0.88	2.00	3.12	B.S.	2.0
4.00	472535	3/8	1.000	1.000	0.88	2.00	3.12	B.S.	2.0
4.00	2028063	1/2	1.000	1.500	1.38	2.00	3.00	F.S.	3.5
4.00	2025891	5/8	1.000	1.500	1.38	2.00	3.00	F.S.	3.5
4.88	472768	3/8	1.250	1.250	1.12	2.25	4.06	F.S.	3.6
4.88	472777	1/2	1.250	1.250	1.12	2.25	4.06	F.S.	3.6
4.88	472786	5/8	1.250	1.250	1.12	2.25	4.06	F.S.	3.6
5.25	2026427	5/8	1.000	1.500	1.38	2.06	3.88	F.S.	4.0
5.25	2026423	3/4	1.000	1.500	1.38	2.06	3.88	F.S.	4.0
5.88	2023141	5/8	1.500	1.750	1.62	2.50	4.38	F.S.	6.0
5.88	2023143	3/4	1.500	1.750	1.62	2.50	4.38	F.S.	6.0
6.00	472875	1/2	2.000	1.750	1.25	3.12	4.75	F.S.	7.0
7.50	2025892	3/4	1.000	1.500	1.38	2.06	6.31	F.S.	7.5
7.62	473311	3/8	1.000	1.500	1.25	2.38	6.18	D.I.	7.0
7.62	473320	1/2	1.000	1.500	1.25	2.38	6.18	D.I.	7.0
7.62	473339	5/8	1.000	1.500	1.25	2.38	6.18	D.I.	7.0
8.00	2023155	1/2	1.500	1.750	1.62	2.56	6.31	F.S.	10.0
8.00	2023159	5/8	1.500	1.750	1.62	2.56	6.31	F.S.	10.0
8.00	2023163	3/4	1.500	1.750	1.62	2.56	6.31	F.S.	10.0
8.00	2023404	3/4	2.000	2.313	2.12	3.25	6.12	F.S.	12.5
9.88	2026433	1/2	1.500	1.750	1.62	2.56	8.31	F.S.	14.5
9.88	2023179	5/8	1.500	1.750	1.62	2.56	8.31	F.S.	14.5
9.88	2023181	3/4	1.500	1.750	1.62	2.56	8.31	F.S.	14.5
9.88	2023436	3/4	2.000	2.313	2.18	3.50	8.12	F.S.	15.0
12.00	2023248	5/8	1.500	1.750	1.62	3.25	10.20	F.S.	18.0
12.00	474365	5/8	2.250	1.750	1.62	4.50	10.12	R.F.	16.0
12.00	2023236	3/4	1.500	1.750	1.62	3.25	9.75	F.S.	18.0
12.00	474374	3/4	2.250	1.750	1.62	4.50	9.75	R.F.	16.0
14.00	2026445	5/8	1.500	1.750	1.62	3.25	12.00	R.F.	20.0
14.00	4200563	5/8	2.000	1.750	1.62	4.50	12.12	R.F.	31.0
14.00	4200572	3/4	2.000	1.750	1.62	4.50	11.75	R.F.	31.0
14.00	474784	7/8	1.500	1.750	1.62	3.25	12.25	R.F.	20.0
16.00	4200705	7/8	2.500	2.313	2.18	4.50	12.94	R.F.	48.0
18.00	4201438	7/8	2.750	2.313	2.18	5.50	14.94	R.F.	42.7
18.00	4200867	1	2.750	2.313	2.18	5.50	14.88	R.F.	66.0

\* Without flame harden groove

Material: B.S.=Bar Steel, C.I.=Cast Iron, F.S.=Forged Steel, D.I.=Ductile Iron, C.S.=Cast Steel, P.M.=Powdered Metal, R.F.=Roll-Forged.



Custom sheaves are available.

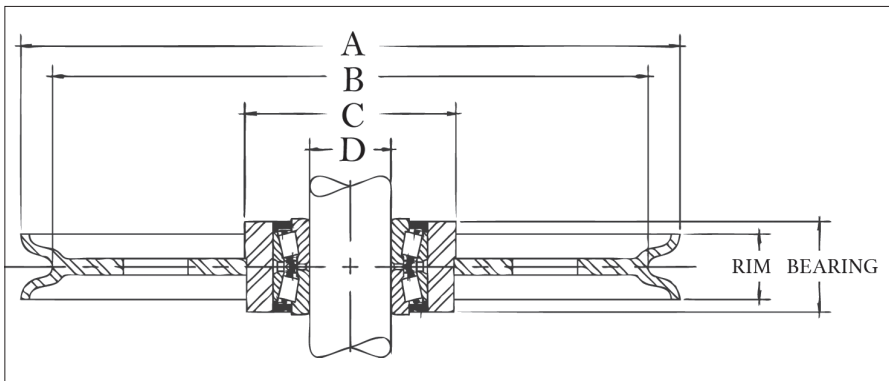

APPLICATION AND WARNING INFORMATION  
SECTION 17

### McKissick® Tapered Bearing Sheaves

- Roll-Forged sheaves are available in sizes up to 78" in diameter.
- Tapered Bearing Sheaves are designed to operate on shafts machined to, and no bearing or bushing is installed.
- Applications should provide for tightening separator plates against bearing cones to adjust and insure proper function of bearing.

"A" Nominal Outside Diameter (in)	Stock Number	Wire Rope Diameter (in)	"D" Shaft Size (in)	Bearing Width (in)	Rim Width (in)	"C" Nominal Hub Outside Diameter (in)	"B" Nominal Tread Diameter (in)	Material	Approx. Weight (lb)
4.88	480269	3/8	0.750	1.375	1.12	2.25	4.06	F.S.	3.6
7.00	480777	1/4	0.750	1.375	0.75	2.38	6.25	B.S.	9.0
8.00	481017	1/2	0.750	1.375	1.25	2.44	6.62	F.S.	7.0
8.50	481044	3/8	0.750	1.375	1.00	2.75	7.50	D.I.	7.5
12.00	481455	3/4	1.500	2.313	2.18	4.50	9.75	R.F.	24.0
12.00	481446	7/8	1.500	2.313	2.18	4.50	10.25	R.F.	24.0
16.00	4302793	1/2	2.000	2.938	2.50	5.75	14.25	R.F.	50.0
16.00	4300599	3/4	2.000	2.938	2.50	5.75	13.38	R.F.	55.0
16.00	4300018	7/8	1.500	2.313	2.18	4.50	12.94	R.F.	37.0
16.00	4300054	1	2.000	2.938	2.50	5.75	13.38	R.F.	42.0
18.00	4300081	3/4	2.000	2.938	2.18	6.50	16.00	R.F.	40.0
20.00	4300161	3/4	2.000	2.938	2.12	6.50	18.00	R.F.	87.0
20.00	4300189	1	2.000	2.938	2.12	6.50	16.50	R.F.	84.0
24.00	*4302720	5/8	2.755	2.938	1.50	6.50	21.75	R.F.	136
24.00	4300312	7/8	4.250	3.500	3.12	8.00	20.88	R.F.	125
24.00	4300321	1	4.250	3.500	3.12	7.62	21.12	R.F.	125
24.00	4300401	1-1/8	2.755	2.938	2.75	6.50	20.06	R.F.	80.0
24.00	4300330	1-1/8	4.250	3.500	3.12	8.00	20.06	R.F.	125
30.00	4300483	7/8	4.250	3.500	3.12	8.00	27.00	R.F.	140
30.00	4300492	1	4.250	3.500	3.12	7.62	26.50	R.F.	210
30.00	4300526	1	5.625	3.688	3.12	9.50	27.00	R.F.	190
30.00	4300508	1-1/8	4.250	3.500	3.12	8.00	27.00	R.F.	140
30.00	4300704	1-1/4	5.625	3.688	3.12	9.50	26.38	R.F.	140

 Custom sheaves are available.

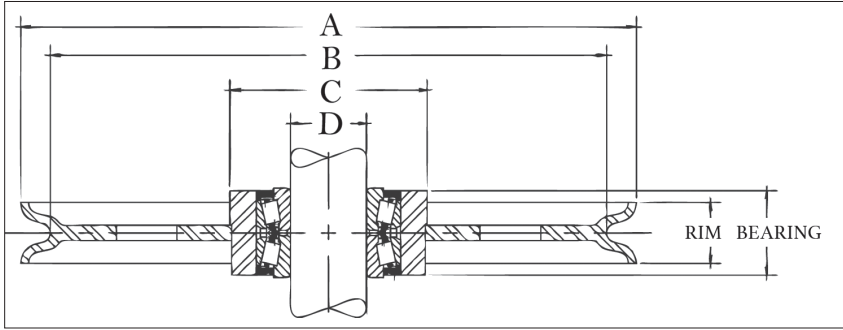

APPLICATION AND WARNING INFORMATION  
SECTION 17

**McKissick® Plain Bore Oilfield Sheaves for Tapered Bearings**

- Roll-Forged sheaves are available in sizes up to 78" in diameter.
- Applications should provide for tightening separator plates against bearing cones to adjust and insure proper function of bearing.
- Each sheave in the table below has a machined bore sized to accept the respective bearing number shown.
- The sheaves are provided from the factory plain bore (the bearings are not included).

"A" Nominal Outside Diameter (in)	Stock Number	Wire Rope Diameter (in)	Bore Information			Bearing Width (in)	Rim Width (in)	"C" Nominal Hub Outside Diameter (in)	"B" Tread Diameter (in)	Material	Approx. Weight (lb)
			"D" Bore Diameter (in)	Bearing Info. (Bearing not Included)							
				Shaft Diameter (in)	Bearing Description						
20	2030311	9/16	4.722	2.756	NA-483-SW-472-D	2.750	2.75	6.50	17.62	R.F.	80
20	2029285	5/8	4.722	2.756	NA-483-SW-472-D	2.750	2.75	6.50	17.81	R.F.	75
24	2030941	9/16	6.498	4.250	NA56425-SW-56650D	3.375	3.12	8.00	21.62	R.F.	103
24	2030905	5/8	6.498	4.250	NA56425-SW-56650D	3.375	3.00	8.00	22.00	R.F.	117
24	2027885	9/16	6.498	4.250	NA56425-SW-56650D	3.375	3.12	8.00	21.62	R.F.	90
24	2027887	5/8	6.498	4.250	NA56425-SW-56650D	3.375	2.75	8.00	22.00	R.F.	80
24	2027880	7/8	6.498	4.250	NA56425-SW-56650D	3.375	3.12	8.00	20.94	R.F.	125
24	2023993	1	6.498	4.250	NA56425-SW-56650D	3.375	3.12	9.00	21.12	R.F.	110
30	2026299	1	6.498	4.250	NA56425-SW-56650D	3.375	3.12	8.50	26.50	R.F.	190
30	2026036	1-1/8	6.498	4.250	NA56425-SW-56650D	3.375	3.12	9.00	26.06	R.F.	230
30	2026230	1	7.873	5.625	NA48685-SW/48620	3.500	3.12	10.25	26.50	R.F.	255
30	2026003	1-1/8	7.873	5.625	NA48685-SW/48620	3.500	3.12	10.25	26.06	R.F.	255
30	2030906	1	8.873	6.500	NA46790-SW-46720	3.625	3.37	10.25	26.50	R.F.	185
30	2030907	1-1/8	8.873	6.500	NA46790-SW-46720	3.625	3.37	12.00	26.06	R.F.	265
30	2027941	1	6.498	4.250	NA56425-SW-56650D	3.375	3.12	9.00	26.50	R.F.	150
30	2027945	1-1/8	6.498	4.250	NA56425-SW-56650D	3.375	3.12	9.00	26.06	R.F.	200
30	2030274	1	7.873	5.625	NA48685-SW/48620	3.500	3.12	10.25	26.50	R.F.	161
30	2030260	1-1/8	7.873	5.625	NA48685-SW/48620	3.500	3.12	10.25	26.06	R.F.	218
36	2030942	1	7.873	5.625	NA48685-SW/48620	3.500	3.25	10.25	33.12	R.F.	350
36	2030908	1-1/8	7.873	5.625	NA48685-SW/48620	3.500	3.25	10.25	33.62	R.F.	350
36	2030943	1	8.873	6.500	NA46790-SW-46720	3.625	3.12	11.50	33.12	R.F.	353
36	2029390	1-1/8	8.873	6.500	NA46790-SW-46720	3.625	3.25	11.00	32.62	R.F.	300
36	2029392	1-1/4	8.873	6.500	NA46790-SW-46720	3.625	3.25	11.00	32.25	R.F.	300
36	2030944	1	10.873	8.000	LM241149NW/241110-D	3.625	3.12	14.00	33.12	R.F.	370
36	2030909	1-1/8	10.873	8.000	LM241149NW/241110-D	3.625	3.50	14.00	32.06	R.F.	358
36	2030945	1-1/4	10.873	8.000	LM241149NW/241110-D	3.625	3.37	14.00	32.25	R.F.	330
36	2030282	1	7.873	5.625	NA48685-SW/48620	3.500	3.25	10.25	33.12	R.F.	240
36	2030284	1 1/8	7.873	5.625	NA48685-SW/48620	3.500	3.25	10.25	32.62	R.F.	250
42	2030946	1-1/8	8.873	6.500	NA46790-SW-46720	3.625	3.25	12.00	38.62	R.F.	460
42	2030947	1-1/4	8.873	6.500	NA46790-SW-46720	3.625	3.25	11.50	38.25	R.F.	470
42	2030948	1-1/8	10.873	8.000	LM241149NW/241110-D	3.625	3.25	14.00	38.62	R.F.	465
42	2030949	1-1/4	10.873	8.000	LM241149NW/241110-D	3.625	3.25	14.00	38.25	R.F.	460
42	2030950	1-1/8	12.873	9.250	NA8575SW-8520CD	4.500	3.50	16.00	38.62	R.F.	465
42	2030951	1-1/4	12.873	9.250	NA8575SW-8520CD	4.500	3.38	16.00	38.25	R.F.	475
44	2030952	1-1/8	10.873	8.000	LM241149NW/241110-D	3.625	3.38	14.00	40.06	R.F.	615
44	2030953	1-1/4	10.873	8.000	LM241149NW/241110-D	3.625	3.00	14.00	40.25	R.F.	545
48	2030954	1-1/8	10.873	8.000	LM241149NW/241110-D	3.625	3.25	14.00	44.62	R.F.	580
48	2030955	1-1/4	10.873	8.000	LM241149NW/241110-D	3.625	2.75	14.00	44.25	R.F.	512
48	2030956	1-1/4	13.686	10.000	LM249747NW/LM249710D	3.875	3.25	17.00	44.25	R.F.	640
50	2030938	1-1/4	10.873	8.000	LM241149NW/241110-D	3.625	3.37	14.00	46.25	R.F.	765
50	2030957	1-1/4	13.686	8.000	LM241149NW/241110-D	3.875	3.25	17.00	46.25	R.F.	765
50	2030958	1-3/8	13.686	10.000	LM249747NW/LM249710D	3.875	3.75	17.00	45.62	R.F.	735
55	2030959	1-1/8	12.873	9.250	NA8575SW-8520CD	4.500	3.50	16.00	51.06	R.F.	890
55	2030960	1-1/4	12.873	9.250	NA8575SW-8520CD	4.500	3.38	16.00	51.25	R.F.	825
55	2030961	1-1/4	13.686	10.000	LM249747NW/LM249710D	3.875	3.50	19.00	51.25	R.F.	588
60	2030879	1-1/4	13.686	10.000	LM249747NW/LM249710D	3.875	3.25	17.00	56.25	R.F.	1095
60	2030880	1-3/8	13.873	10.500	LM251649NW/251610-D	4.125	3.62	19.00	55.88	R.F.	1175
60	2030881	1-3/8	15.498	12.000	L357049NW/L357010D	4.125	3.75	19.00	55.88	R.F.	1175
60	2030875	1-1/2	13.686	10.000	LM249747NW/LM249710D	3.875	3.50	19.00	55.50	R.F.	1175

\*\*Crown Sheaves contain lightning holes.



Custom sheaves are available.