



McKISSICK SHEAVES

With Product Warnings and Application Information



"There is No Equal"



The Market Leader: Yesterday Today and Tomorrow

McKissick Sheaves

HISTORY & EXPERIENCE

The ability to match the sheave design and manufacturing process to meet the application requirements requires experience. It also requires the ability to creatively use this experience and manufacturing resources to provide the best solution.

THE COMPETITION

- Ask:** *What is their history and experience?*
- Ask:** *What processes do they have available to draw upon?*
- Ask:** *What technical experience do they have available to provide technical solutions to technical demands?*



McKissick has provided sheaves to energy and lifting industries since the early 1900's. Since McKissick became part of Crosby in the mid 1900's there has been a continuous history of product and process development. Crosby invented the roll forged sheave in 1978 and continues to be a leader today in sheave design and manufacturing process.

DELIVERY & ACCESSIBILITY

Many energy and lifting sheave applications require short delivery times and delivery to locations around the world. Response times require flexible manufacturing resources. Access around the world requires not only logistics experience and capabilities, but also requires manufacturing resources strategically located around the world.

THE COMPETITION

- Ask:** *How do they support short deliveries?*
- Ask:** *What is their experience providing worldwide delivery?*
- Ask:** *What resources do they have in key areas of the world?*



Crosby-McKissick stocks key raw materials and has an extensive bank of tooling and sufficient manufacturing capacity to support short deliveries. Crosby has McKissick block and sheave centers that serve their local markets in Tulsa, Oklahoma (USA); Putte, Belgium; Singapore; and Hangzhou, China.

FLEXIBILITY OF DESIGN

Matching the best solution to the application requires the ability to fabricate sheaves by a number of processes:

- 1) Heavy Duty – Roll forged sheaves are hot forged with no splitting stresses at base for sheaves up to 78".
- 2) Heavy Duty – Closed die forged sheaves with machined Wireline groove for sheaves up to 16".
- 3) Extreme Duty – Roll forged sheaves with welded dome reinforcement employ the latest welding technology with no shape cross brace stress concentration areas.
- 4) Heavy Duty fabricated sheaves – With welded rings and reinforced webs utilizing the latest welding technology.
- 5) The ability to provide sheave grooves with 30, 35 and 45 degree profiles as well as other special profile
- 6) The ability to provide bearings to match application: Plain bore, bronze bushed, roller bearings, tapered roller bearings and full complement bearings.
- 7) Heat treatment of Wireline groove to provide wear resistance.

THE COMPETITION

- Ask:** *How do they achieve the performance required with a split or cast sheave?*
- Ask:** *How do they resolve the welding stresses induced when you fabricate the sheave?*
- Ask:** *What sheave groove profile do they provide on a regular basis?*
- Ask:** *Do they have technical expertise to recommend proper sheave bearings?*
- Ask:** *How do they provide for proper Wireline groove life?*



McKissick offers roll forged sheaves that provide an upset metal flow without creating a stress zone at the splitting point. The dome-reinforced sheave design provides for a continuous weld in a circular pattern. McKissick produces sheaves in 30, 35, and 45 degree profiles, and can provide special profiles as required. Extensive experience underwater and in harsh and demanding environments gives McKissick the needed experience in selecting sheaves for all applications. From material selection to hardening of the groove, McKissick sheaves provide the needed wire-line life.

SPECIFICATIONS

Many energy and lifting sheaves must meet standards. These standards include API, ABS, DIN, DNV and ASME. Demanding specifications for sheaves used in demanding applications also include strength, fatigue, impact and non-destructive testing.

THE COMPETITION

- Ask:** *Do they understand and have experience in meeting the industry standards such as API, ABS, DIN, DNV and ASME?*
- Ask:** *Do they have a history of gaining required approvals?*
- Ask:** *Are they licensed to manufacture sheaves to API 8C?*



Crosby McKissick has achieved API Q1, and TS29001 Status, and is licensed to manufacture sheaves to API 8C. Sheaves are frequently provided to API, DNV and ABS requirements.

TECHNICAL SUPPORT & TRAINING

The selection, use, inspection and maintenance of sheaves requires technical support. This technical support includes engineering services, training support and the ability to meet the various industry requirements around the world.

THE COMPETITION

- Ask:** *What technical support do they provide?*
- Ask:** *Where is this support provided from?*
- Ask:** *What training is available to support the selection, use, inspection and maintenance of sheaves?*



Crosby has technical and operational support available from each of our McKissick Block and Sheave Centers around the world. Crosby provides extensive training through our one day Block and Sheave Clinics and our two-day Heavy Lift Seminars. Industry-specific training is also provided.

Remember: "When buying Crosby, you're buying more than product, you're buying Quality."



VALUE ADDED

McKissick® Roll-Forged Heavy Duty Sheaves are made by upsetting and forming the groove and flange walls in multiple steps, eliminating the need to split and weaken the groove. This exclusive forging process adds extra strength to the critical groove section.

McKissick Domed Reinforced Extreme Duty Roll Forged Sheaves are welded in a circular pattern thus eliminating the higher stresses created by welding ribs or other forms of stiffeners.

McKissick Heavy Duty Sheaves are available with machined groove rings or machine forged rings utilized for the rim or hub.

McKissick Heavy Duty Closed-Die Forged Sheaves offer the performance of closed-die forging with the precision machining capabilities of CNC machinery.

McKissick Normal Duty Malleable Cast Sheaves provide economical solutions for normal service applications.

McKissick Sheaves come in a variety of sizes to suit your specific applications. Crosby offers many sheaves as standard and these are shown in the pages that follow. For applications that require unique specifications, Crosby can make minor modifications to many of the sheaves listed at a reasonable charge. We can also custom design and manufacture sheaves to your exact requirements. McKissick roll forged sheaves can be furnished balanced or with lightening holes at a reasonable charge on request.

Crosby's Hardening Technique is a science. It provides a precise maximum hardness for wear-resistance across the wire rope contact area. The McKissick sheave groove is flame hardened to a minimum 35 Rockwell C for a 140° contact area with the wire rope (upon special request the McKissick sheave groove can be flame hardened to a minimum 50 Rockwell C for a 150° contact area with the wire rope). The solid steel plate provides the ideal surface for flame hardening and a closer tolerance fit to the wire rope to reduce fatigue and wear.

The McKissick Hub is stepped to eliminate stress failure in the weld, common in traditional hub designs. The hub is pressed into place with complete metal-to-metal contact. This helps ensure an accurate alignment to the hub's axis so there is no wobble or lopping of the rotating sheave. The precision aligned hub / sheave wheel combination adds to the bearing life and keeps the sheave on the job longer.

McKISSICK® STANDARD BEARINGS



(B) Bronze Bushing



(R) Roller Bearings



(W) Roller Bearing
with Thrust Washers



(C) Full Complement Cylindrical
Roller Bearing



(T) Tapered Roller
Bearing

McKISSICK® Wireline GROOVE PROFILES

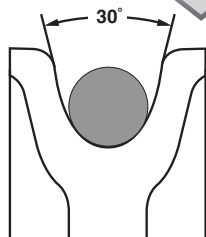

API STYLE
30 degrees

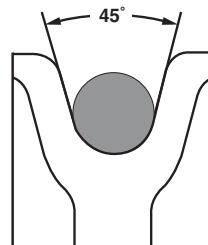

EUROPEAN STYLE
45 degrees

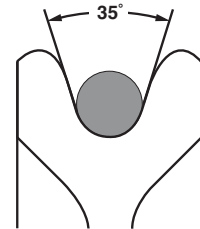

AISE STYLE
35 degrees

Custom sheaves are available. See page 287 for ordering details.

DO NOT BE FOOLED

The Elements of a Superior Sheave

Every McKissick® Roll-Forged sheave starts as a single piece of AISI C-1035 carbon steel plate. Utilizing a time proven proprietary roll forging process that adds extra strength to the critical groove section, the sheave is formed from a precision flame cut blank. The hub is then pressed into place with complete metal-to-metal contact and secured with a deep penetrating weld to ensure proper fit and longer life. Before the McKissick® name is added, each sheave is thoroughly inspected to meet applicable industry and Crosby® quality standards.

McKissick® Roll-Forged sheaves contain the following critical standard features required to meet your demanding applications:

1 Smooth radius at the rim provides superior transition from outside diameter to groove - eliminating sharp corners that can damage rope

- Cold formed split steel sheaves may contain a sharp transition radius at rim of sheave



2 Size for size, McKissick® Roll-Forged sheaves have a thicker section under the tread of the Wireline groove - providing more substantial support of the Wireline

- Cold formed split steel sheaves are limited to a thinner section thickness under the groove, reducing sheave life in heavy service conditions
- Thinner sections produce a sharp corner under the tread, resulting in potential stress risers

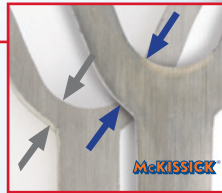

3 Thicker web on sheave provides required stiffness to support a stronger sheave that contains thicker flange sections

- The thinner web on cold formed split steel sheaves, inherent to the process, does not support thicker flange section
- The sharp, pointed cutter used in forming the groove during the cold formed split steel process may produce a concealed crack in the bottom of the groove

	McKissick®	Cold Formed Split Steel
Smooth Radius Edge - Better fit, less wear on rope	4	
Thicker Fleet Section - Better support, stronger sheave groove	4	
Deep Penetrating Weld at Hub - Longer life	4	
Flame Hardened Groove - Higher Rockwell C rating	35Rc	14Rc
Roll Forging Process - Provides superior grain flow	4	



McKISSICK®
Roll-Forged
Sheave

There is no sheave like a McKissick® Roll-Forged Sheave

...into thinking all sheaves produce the same results.

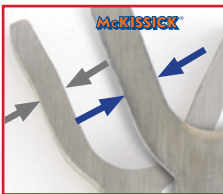

4 Heavier flange sections - provide a much stronger wire rope groove and maintain proper consistent groove angles, ensuring long term Wireline performance

- Cold formed split steel sheaves tend to have flange sections that are thinner as well as variations in thickness on the same sheave, resulting in less than desired performance during critical applications
- Cold formed split steel sheaves are limited to a maximum flange thickness of 50% of web section

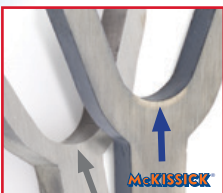

5 Minimum 35Rc for higher hardness in the bottom of the groove - results in less wear to the sheave, thus extending life of Wireline

- Unless requested at time of order, cold formed split steel sheaves have a much lower hardness rating (approx. 14Rc)
- The standard material used in cold formed split steel process may not allow higher hardness in groove



6 Precision alignment of hub with blank, then finished with a deep penetrating weld - ensuring proper fit, longer life and confidence during the most extreme of applications

Cold Formed Split Steel Sheave

Additional Important Features of McKissick® Roll-Forged Sheaves

- The grain flow associated with the McKissick® Roll-Forged sheave process results in excellent performance properties.
- Each sheave is permanently marked with “McKissick®”, sheave outside diameter, Wireline size and Product Identification Code (PIC) that provides complete material traceability.

**Crosby® and McKissick® Roll-Forged Sheaves
Reliability You Can Depend On**



Crosby®

thecrosbygroup.com

HEAVY DUTY SHEAVES

FROM 12" THROUGH 78"

Stepped Hub Design Proves Better

The McKissick hub is stepped to eliminate stress failure in the weld, common in traditional hub designs. The hub is pressed into place with complete metal-to-metal contact. This helps ensure an accurate alignment to the hub's axis so there is no wobble or lopping of the rotating sheave. The precision aligned hub/sheave wheel combination adds to the bearing life and keeps the sheave on the job longer.

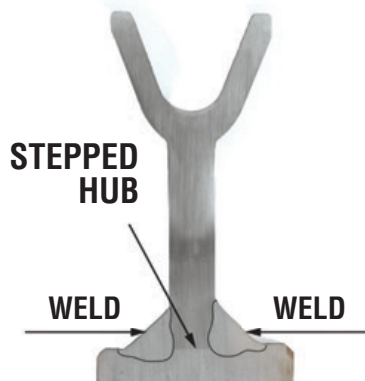

Closed Die Upset and Roll Forged – Not Split

Upsetting and roll forging forms the groove and flange walls in multiple steps, eliminating the need to split and weaken the groove. This exclusive forging process adds extra strength to the critical groove section. You can count on a McKissick sheave to give maximum life performance, because it's forged to distribute the wire rope forces evenly over an accurately formed load surface. Plus, uniformity of the roll forged groove adds longer wire rope life.

Full Range of Standard Sheave Sizes

McKissick Roll-Forged sheaves are available in a full range of sizes from 12 inches to 78 inches, and bearing styles and prices that best fit your application. Crosby also manufactures custom McKissick sheaves and can make minor modifications to standard sheaves as needed for special applications.



Solid Steel – No Casting

Every McKissick sheave starts as a single piece of solid carbon steel plate. It's flame-cut from closely checked stock, so there's no inherent web/rim flaw as you find in cast sheaves. There's better balance and better distribution of forces with a McKissick Roll-Forged sheave too. Casting can result in groove wall variations – either too thick or too thin – causing uneven stresses and early failure.

**NOTE: Custom Sheaves are Available.
See Page 287 for Ordering Details.**

Flame Hardened Groove

Crosby's hardening technique is a science. It provides a precise maximum hardness for wear-resistance across the wire rope contact area. The McKissick sheave groove is flame hardened to a minimum 35 Rockwell C for a 140° contact area with the wire rope (upon special request the McKissick sheave groove can be flame hardened to a minimum 50 Rockwell C for a 150° contact area with the wire rope). The solid steel plate provides the ideal surface for flame hardening and a closer tolerance fit to the wire rope to reduce fatigue and wear.

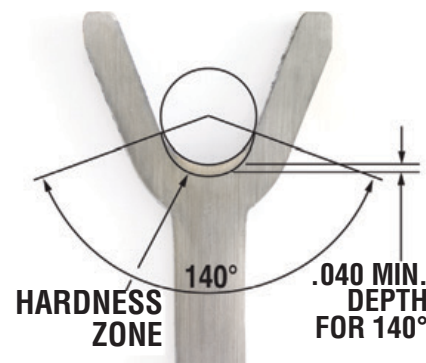

Bearing Selection to Match Your Job Requirement

The McKissick Roll-Forged sheave is available in the following configurations

- Plain bore
- Bronze bushed
- Roller bearing
- Tapered roller bearing
- Lubrication thru hub
- Key ways
- Set screws
- Full Complement Bearing



Licensed Under
API Spec 8C-0021

Sheaves are available to API 8C.



DOMED SHEAVES 24" AND LARGER

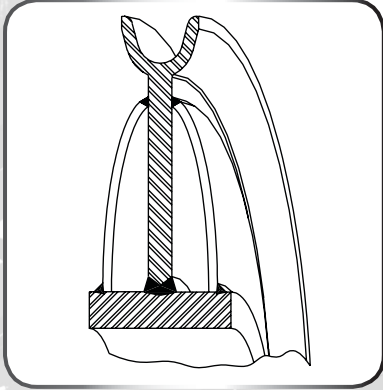

Eliminates High Stress Weld Intersections

McKissick® Domed Roll-Forged sheaves are welded in a circular pattern thus eliminating the higher stresses created by welding ribs or other forms of stiffeners.



U.S. Patents D621, 240

Large Range of Sheave Sizes Available

McKissick Domed reinforced Roll-Forged sheaves are available in sizes 24 inches and larger, and bearing styles that best fit your extreme duty applications.



Roll Forged Sheave and Latest in Welding Technology

McKissick Domed Roll-Forged sheaves have the strength, fatigue properties and rigidity needed for those "extreme duty sheaves" with high working stress and side loading.

McKissick® Fabricated Sheaves

Custom sheaves are available. See page 287 for ordering details.

McKissick
Sheaves

HEAVY DUTY SHEAVES AVAILABLE THROUGH 116" IN OUTSIDE DIAMETER

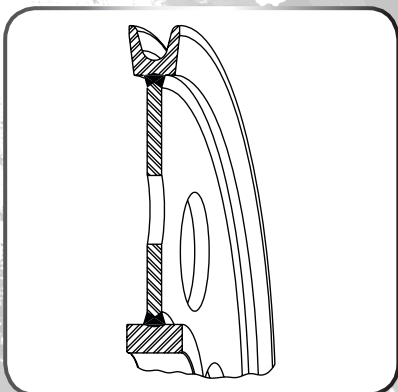

The Best Solution for Large Sheave Sizes

McKissick fabricated sheaves are available with machined groove rings or machined forged rings utilized for the rim or hub.

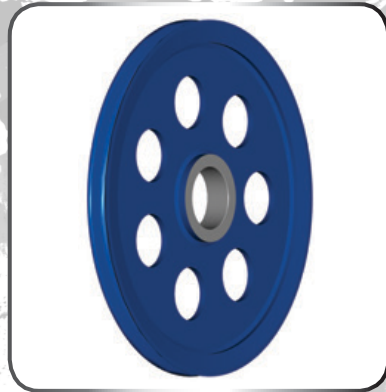

Large Range of Sheave Sizes Available

McKissick fabricated sheaves are available in multiple sizes, and bearing styles that best fit your heavy duty applications

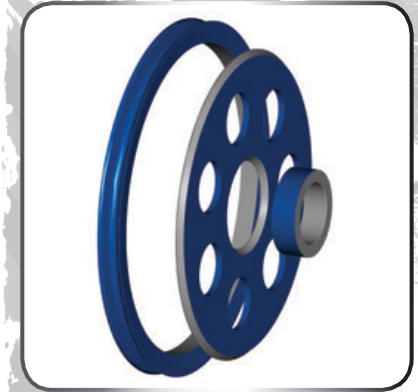

For Larger Sheave Sizes

McKissick fabricated sheaves are an excellent solution when the required sheave size is too large to be manufactured by the roll forged sheave process.

HEAVY DUTY SHEAVES
FROM 4" THROUGH 12"

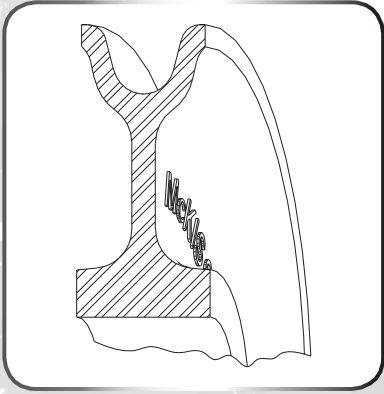

Closed Die Forging

McKissick closed die forged sheaves offer the performance of closed die forging with the precision machining capabilities of CNC machinery.

For Smaller Sheaves in Heavy Duty Application

McKissick closed die forged sheaves are available in sizes from 4 inches to 12 inches. An extremely effective solution for heavy duty applications where high loads are applied.

Any of the bearings we offer with the roll forged sheaves are available.



Select Range of Sheave Sizes Available

McKissick closed die forged sheaves are available in sizes from 4 inches to 12 inches, and bearing styles that best fit your heavy duty applications.

McKissick® Ductile Iron Sheaves

Custom sheaves are available. See page 287 for ordering details.

NORMAL SERVICE DUTY SHEAVES
FROM 3" THROUGH 16"

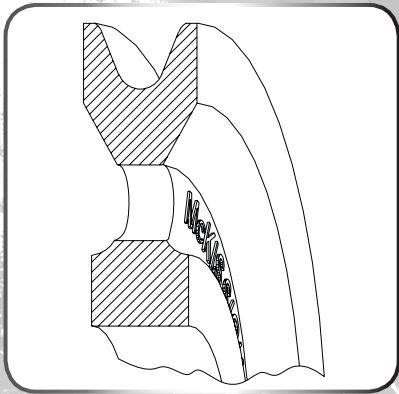

Machined Ductile Iron

McKissick ductile iron sheaves are manufactured with material that meets ASTM A-536.

For Smaller Sheaves in Normal Duty Applications

McKissick ductile iron sheaves are an acceptable solution for light or normal duty applications where sheaves are protected by sheave guards and minimal side loads are applied.

Standard roller bearings and bronze bushings are typically appropriate for use in these applications.

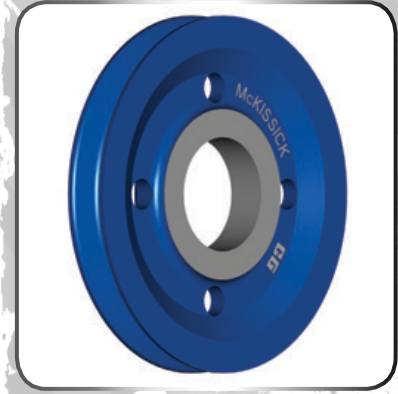

Select Range of Sheave Sizes Available

McKissick ductile iron sheaves are available in sizes from 3 inches to 16 inches, and bearing styles that best fit your normal service duty applications.

McKissick® Sheaves Groove Profile Available

McKISSICK® Wireline GROOVE PROFILES

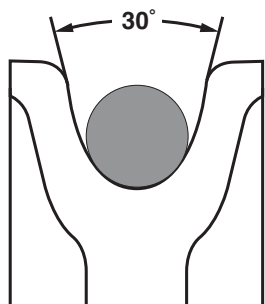

API STYLE
30 degrees

The sheave profile is a very important feature of all sheaves. McKissick manufactures standard sheaves for general use in hoisting wire rope guide applications to minimal API Specifications. The profile includes a groove angle of 30°. This groove profile is used in mobile cranes, drilling rigs, working units, tubing blocks, traveling blocks, crown blocks and many other general hoisting applications.

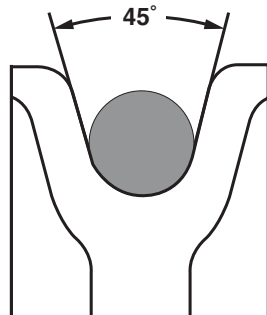

EUROPEAN STYLE
45 degrees

DIN 15061 lifting appliances defines groove profiles for wire rope sheaves

Nominal tread depth is 1.5 times wire rope diameter.

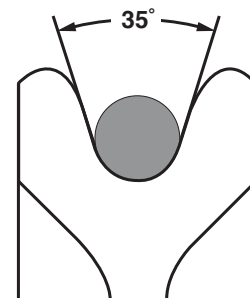

AISE STYLE
35 degrees

McKissick manufactures sheaves to meet the specifications of AISE Standard Number 6. AISE Sheaves must meet specified criteria established by the Association of Iron and Steel Engineers for special use in electric overhead traveling cranes for steel mill service. The profile includes a groove angle of 35°. Dimensional details are also different from the API profile. This groove profile is used in overhead traveling cranes, mobile cranes, portal cranes, power shovels and other equipment using wire rope.

Contact Crosby for additional available groove angles.

McKissick
Sheaves

McKissick® Sheaves Available to API Standards

- McKissick® products has been licensed by the American Petroleum Institute to manufacture Roll-Forged Sheaves under API specifications 8C. In addition, McKissick® Products is API Q1 certified
- McKissick® Products also produces sheaves to the requirements of API 2C.
- API sheaves must meet the criteria established by the American Petroleum Institute for drilling and production hoisting equipment .
- Typical oilfield applications include: Heavy Haul Trucking, Workover and Well Servicing Units, Tubing Blocks, Traveling Blocks, Crown Blocks and Offshore Cranes.

API 8C Requires

- Databook
- Material certs and traceability
- D/d ratio per API RP9B
- MPI
- UT of full penetration weld
- 30° groove angle. Groove depth a minimum 1.33 d and maximum 1.75 d, where d=nominal rope diameter.
- Manufactured by an API-8C licensed facility
- Specific groove radii
- Can be furnished to API 8C PSL1 or PSL2

API 2C Requires

- Material certs and traceability
- D/d ratio 18/1 or greater, based on pitch diameter
- At least 30° groove angle
- Specific groove radii



Licensed Under
API Spec 8C-0021

McKissick® Sheaves Bearings Application Information

(B) Bronze Bushing

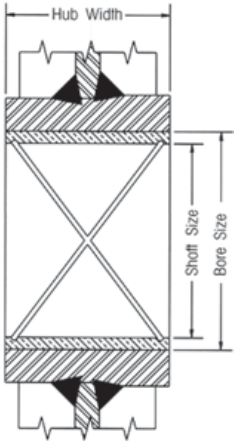

Bronze Bushing

Slow line speed, moderate load and moderate use

- Maximum Bearing Pressure (BP): 4500 PSI
- Maximum Velocity at Bearing (BV): 1200 FPM
- Maximum Pressure Velocity Factor (PV): 55000

$$\text{Formula for BP} = \frac{\text{Line Pull} \times \text{Angle Factor (See Page 383)}}{\text{Shaft Size} \times \text{Hub Width (See example)}}$$



For underwater sheave applications, special bronze bushings are available. Consult the bearing manufacturer for applicable load.

Example:

Using a 14 in. sheave (917191) with a 4600 lb line pull and an 80 degree angle between lines, determine maximum allowable line speed.

$$\text{BP} = \frac{\begin{matrix} \text{(Line Pull)} \\ 4600 \text{ lb} \end{matrix} \times \begin{matrix} \text{(Angle Factor)} \\ 1.53 \end{matrix}}{\begin{matrix} \text{(Shaft Size)} \\ 1.50 \end{matrix} \times \begin{matrix} \text{(Hub Width)} \\ 1.62 \end{matrix}} = 2896 \text{ PSI}$$

$$\text{BV} = \frac{\begin{matrix} \text{(PV Factor)} \\ 55000 \end{matrix}}{\begin{matrix} \text{(BP)} \\ 2896 \end{matrix}} = 19 \text{ FPM}$$

(R) Roller Bearings

ROLLER BEARINGS

Bronze Bushings with "Figure 8" oil grooves are made from S.A.E. 660 bronze for cold finished shafts

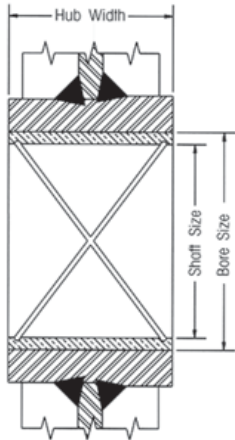

Roller Bearings are designed to operate on shafts carburized to 60 Rockwell C and grounded to +/- .0005 of shaft size.

(W) Roller Bearing with Thrust Washers

STANDARD STRAIGHT ROLLER BEARINGS

Heavier loads, higher speeds, more frequent use, radial loads only.

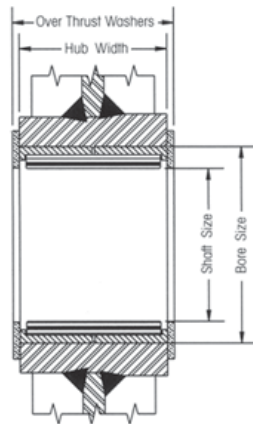

Roller Bearings without inner races are designed to operate on shafts carburized to 60 Rockwell C and grounded to +/- .0005 of shaft size.

(C) Full Complement Cylindrical Roller Bearing

FULL COMPLEMENT, DOUBLE ROW, ROLLER BEARING

Heavy load, high speeds, continuous operation, axial and radial loads.

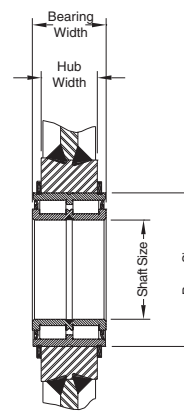

Cylindrical Roller Bearings with snap ring grooves are complete units with outer and inner rings, rib guided cylindrical rollers and sealing rings. They can support axial forces in both directions as well as radial forces. They have high dynamic and static load ratings.

(T) Tapered Roller Bearing

TAPERED ROLLER BEARINGS

Heavy loads, high speeds, continuous operation, axial and radial loads.

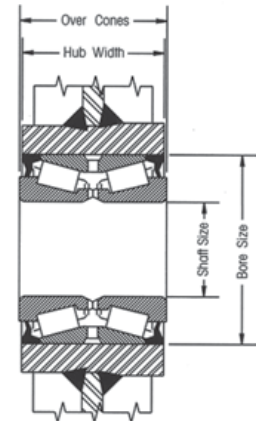

Tapered Bearings are designed to operate on shafts machined to +/- .0005 of shaft size. Applications should provide for tightening separator plates against bearing cones to adjust and insure proper function of bearings.

McKissick® Sheaves Selection Guide

McKissick® Sheaves come in a variety of sizes to suit your specific applications. Crosby offers many sheaves as standard and these are shown in the pages that follow.

For applications that require unique specifications, Crosby can make minor modifications to many of the sheaves listed at a reasonable charge. We can also custom design and manufacture sheaves to your exact requirements. Contact Crosby Sales to order McKissick® sheaves and include the stock number and quantity. For help in finding that standard sheave or for help with special requirements or custom designed sheaves, furnish the following important information:

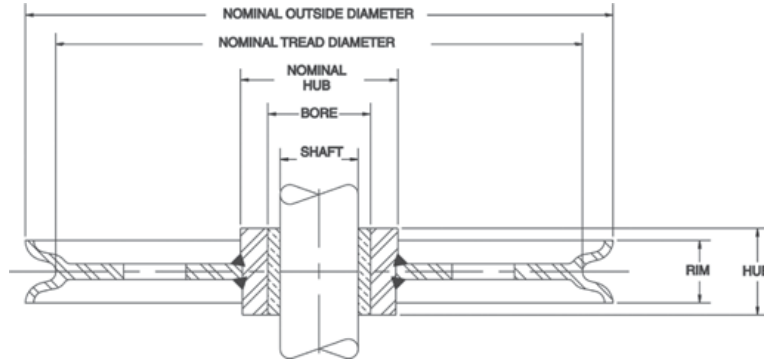

DIMENSIONAL INFORMATION

Nominal Outside Diameter: _____ Wire Rope Size: _____ Rim Width: _____

+ Shaft Size: _____ *Hub Width: _____

Nominal Tread Diameter (Optional): _____ Nominal Hub Diameter (Optional): _____

*Hub width is measured over the cone of the Tapered Bearing Sheaves.

+ Shaft Size is Bore Size on Plain Bore Sheaves.

BEARING TYPE

Bronze Bushing ++ Roller Bearing Tapered Roller Bearing Finish / Plain Bore

Full Complement Cylindrical Roller Bearing Underwater Other

++ Requires hardened and ground shaft

MATERIAL TYPE

Roll-Forged (Flame hardened 14" and larger) Forged Steel Domed

Cast Steel Fabricated Other

APPLICATION INFORMATION

Line Pull: _____ Fleet Angle: _____ Degree of Wrap: _____

Line Speed: _____ Environment: _____ Groove Angle: _____

SPECIAL REQUIREMENTS

Special Testing: _____

Finish: _____

Third Party Inspection / Approval: _____

In USA: Crosby's Special Engineered Product Group at 1-800-777-1555, fax (918) 834-5035, specials@thecrosbygroup.com

In Canada: Crosby Canada at (905) 451-9261

In Europe: N.V. Crosby Europe at 32 15 757125(26).

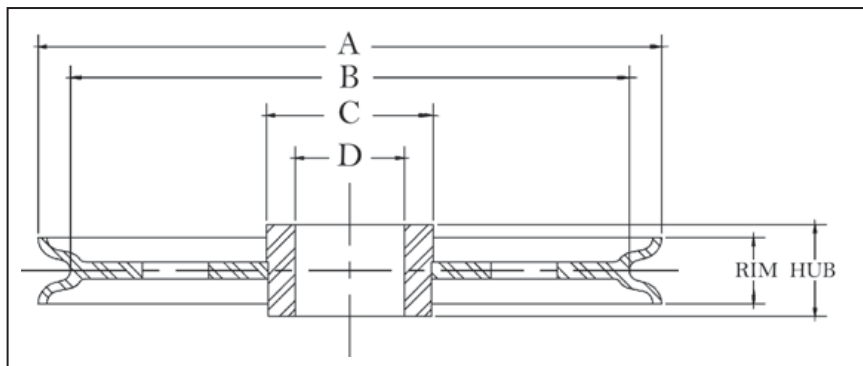

Finished Bore Sheaves

- Roll-Forged™ sheaves are available in sizes up to 78" in diameter.
- McKissick® Finished Bore Sheaves can be equipped with bushings or bearings at an optional charge.
- 14" diameter sheaves and larger are Roll-Forged with flame hardened grooves to minimum Rockwell 35C

"A" Nominal Outside Diameter (in)	Stock Number	Wire Line Size (in)	"D" Bore Size (in)	Hub Width (in)	Rim Width (in)	"C" Nominal Hub Outside Diameter (in)	"B" Nominal Tread Diameter (in)	Material	Approx. Weight (lb)
3	51008	1/4	.752	1-5/16	1-1/4	1-1/8	2-1/16	B.S.	1.00
3	11310	3/8	.752	1-5/16	1-1/4	1-1/8	2-1/16	B.S.	1.00
4	51053	1/8	1.569	1	7/8	2	3-1/8	B.S.	2.00
4	51044	1/4	1.569	1	7/8	2	3-1/8	B.S.	2.00
4	1189	3/8	1.569	1	7/8	2	3-1/8	B.S.	2.00
4	2023185	3/8	1.569	1-1/2	1-3/8	2	3	F.S.	3.50
4	2023182	1/2	1.569	1-1/2	1-3/8	2	3	F.S.	3.50
4	2023187	5/8	1.569	1-1/2	1-3/8	2	3	F.S.	3.50
4-1/4	50553	3/8	.814	1-3/16	15/16	2-1/8	3-1/8	B.S.	2.40
4-1/4	25939	1/2	.814	1-3/16	15/16	2-1/8	3-1/8	B.S.	2.40
4-3/4	51222	5/16	.875	1-9/16	1-3/8	1-1/2	3-5/8	D.I.	3.50
4-3/4	51231	3/8	.875	1-9/16	1-3/8	1-1/2	3-5/8	D.I.	3.50
4-3/4	11622	1/2	.875	1-9/16	1-3/8	1-1/2	3-5/8	D.I.	3.50
4-7/8	2026411	3/8	1.749	1-1/4	1-1/8	2-1/4	4-1/16	F.S.	3.60
4-7/8	62149	3/8	1.848	1-5/16	1-1/8	2-1/4	4-1/16	F.S.	2.50
4-7/8	2026413	1/2	1.749	1-1/4	1-1/8	2-1/4	4-1/16	F.S.	3.60
4-7/8	2026409	5/8	1.749	1-1/4	1-1/8	2-1/4	4-1/16	F.S.	3.60
5	51071	5/16	1.125	1	7/8	1-1/2	4	F.S.	2.50
5	51062	3/8	1.125	1	7/8	1-1/2	4	F.S.	2.50
5	25948	7/16	1.125	1	7/8	1-1/2	4	F.S.	2.50
5-1/4	2026426	5/8	1.569	1-1/2	1-3/8	2-1/16	3-7/8	F.S.	4.00
5-1/4	2026422	3/4	1.569	1-1/2	1-3/8	2-1/16	3-7/8	F.S.	4.00
5-7/8	2023133	5/8	1.875	1-3/4	1-5/8	2-1/2	4-3/8	F.S.	6.00
5-7/8	2023136	3/4	1.875	1-3/4	1-5/8	2-1/2	4-3/8	F.S.	6.00
5-7/8	2023134	7/8	1.875	1-3/4	1-5/8	2-1/2	4-3/8	F.S.	6.00
6	51124	3/8	1.625	1-1/8	1	2-1/4	4-15/16	F.S.	4.00
6	51375	1/2	1.375	1-1/2	1-1/4	3-1/8	4-3/4	B.S.	7.00
6	13014	1/2	1.625	1-1/8	1	2-1/4	4-15/16	F.S.	4.00
6	60695	1/2	2.375	1-3/4	1-1/4	3-1/8	4-3/4	F.S.	4.70
6	2023263	5/8	2.500	2-5/16	2-3/16	3-1/8	4-1/4	F.S.	9.50
6	1410	3/4	1.375	1-1/2	1-1/4	3-1/8	4-3/4	B.S.	7.00
6	2023257	3/4	2.500	2-5/16	2-3/16	3-1/8	4-1/4	F.S.	9.50
6	2023261	7/8	2.500	2-5/16	2-3/16	3-1/8	4-1/4	F.S.	9.50
7	61872	1/4	1.848	1-5/16	3/4	2-3/8	6-1/4	B.S.	4.00
7	51437	1/4	1.875	1-3/8	3/4	2-3/8	6-1/4	B.S.	6.20
7	3203	3/8	1.875	1-3/8	3/4	2-3/8	6-1/4	B.S.	6.20
7-1/2	2026452	5/8	1.569	1-1/2	1-3/8	2-1/16	6-15/16	F.S.	7.50
7-1/2	2026450	3/4	1.569	1-1/2	1-3/8	2-1/16	6-5/16	F.S.	7.50
7-5/8	51605	3/8	1.569	1-1/2	1-1/4	2-3/8	6-3/16	D.I.	7.00
7-5/8	5498	1/2	1.569	1-1/2	1-1/4	2-3/8	6-3/16	D.I.	7.00
7-5/8	51614	5/8	1.569	1-1/2	1-1/4	2-3/8	6-3/16	D.I.	7.00

Custom sheaves are available. See page 287 for ordering details.

McKissick® Finished Bore Sheaves

"A" Nominal Outside Diameter (in)	Stock Number	Wire Line Size (in)	"D" Bore Size (in)	Hub Width (in)	Rim Width (in)	"C" Nominal Hub Outside Diameter (in)	"B" Nominal Tread Diameter (in)	Material	Approx. Weight (lb)
8	2023466	1	2.750	2-1/2	2-3/8	4	5-1/4	F.S.	15.0
8	6353	1-1/8	2.750	2-1/2	2-3/8	4	5-3/8	F.S.	15.0
8	2023152	3/4	1.876	1-3/4	1-5/8	2-9/16	6-5/16	F.S.	10.0
8	61710	1/2	1.848	1-5/16	1-1/4	2-7/16	6-5/8	F.S.	8.00
8	51589	1/2	1.875	1-1/2	1-3/8	2-7/16	6-5/8	F.S.	7.00
8	2023144	1/2	1.876	1-3/4	1-5/8	2-9/16	6-5/16	F.S.	10.0
8	51598	5/8	1.875	1-1/2	1-3/8	2-7/16	6-5/8	F.S.	7.00
8	2023146	5/8	1.876	1-3/4	1-5/8	2-9/16	6-5/16	F.S.	10.0
8	5194	3/4	1.875	1-1/2	1-3/8	2-7/16	6-5/8	F.S.	7.00
8	2028226	3/4	2.500	2-5/16	2-1/8	3-1/4	6-1/8	F.S.	12.5
8	2023403	3/4	2.561	2-5/16	2-1/8	3-1/4	6-1/8	F.S.	10.3
8	2023385	7/8	2.500	2-5/16	2-1/8	3-1/4	6-1/8	F.S.	12.5
8	2023765	1-1/8	4.000	2-1/2	2-3/8	5	5-7/16	C.S.	15.0
8-1/2	61747	3/8	1.848	1-5/16	1	2-3/4	7-1/2	D.I.	11.0
9-3/4	2026492	3/8	2.998	2-3/16	1	3-3/4	8-3/4	F.S.	9.00
9-7/8	51918	3/8	3.000	1-3/4	1-1/8	3-3/4	8-9/16	F.S.	14.0
9-7/8	51749	1/2	1.375	1-1/2	1-3/8	3-1/4	8-1/2	F.S.	9.50
9-7/8	2023154	1/2	1.875	1-3/4	1-5/8	2-9/16	8-5/16	F.S.	14.5
9-7/8	6040	1/2	3.000	1-3/4	1-1/8	3-3/4	8-9/16	B.S.	14.0
9-7/8	5675	5/8	1.375	1-1/2	1-3/8	3-1/4	8-1/2	F.S.	9.50
9-7/8	2023169	5/8	1.875	1-3/4	1-5/8	2-9/16	8-5/16	F.S.	14.5
9-7/8	2023173	3/4	1.875	1-3/4	1-5/8	2-9/16	8-5/16	F.S.	14.5
9-7/8	2023435	3/4	2.561	2-5/16	2-3/16	3-1/2	8-1/8	F.S.	16.1
9-7/8	2023419	7/8	2.500	2-5/16	2-3/16	3-1/2	8-1/8	F.S.	15.0
9-7/8	2023427	1	2.500	2-5/16	2-3/16	3-1/2	8-1/8	F.S.	15.0
10	2023484	1-1/8	2.750	2-1/2	2-3/8	4	7-3/8	F.S.	19.0
10	2023784	1-1/8	4.000	2-1/2	2-3/8	5-3/4	7-3/8	F.S.	27.0
11-7/8	62096	1/4	2.998	2-3/16	1	3-3/4	10-3/4	D.I.	12.0
11-7/8	6193	3/8	3.000	2-5/16	1	3-3/4	10-3/4	D.I.	11.2
12	2023247	5/8	1.876	1-3/4	1-5/8	3-1/4	10-1/8	F.S.	18.0
12	2023234	3/4	1.876	1-3/4	1-5/8	3-1/4	9-3/4	F.S.	18.0
12	2023251	7/8	1.876	1-3/4	1-5/8	3-1/4	10-1/4	F.S.	18.0
12	2026531	5/8	3.000	1-3/4	1-5/8	4-1/2	10-1/8	R.F.	16.0
12	52285	3/4	3.000	1-3/4	1-5/8	4-1/2	9-3/4	R.F.	16.0
12	2030851	5/8	2.500	2-5/16	2-3/16	4-1/2	10-1/8	R.F.	24.0
12	2030847	3/4	2.500	2-5/16	2-3/16	4-1/2	9-3/4	R.F.	24.0
12	60007	3/4	2.750	2-5/16	2-3/16	4-1/2	9-3/4	R.F.	24.0
12	2026537	3/4	2.998	2-5/16	2-3/16	4-1/2	9-3/4	R.F.	24.0
12	74724	3/4	2.999	2-5/16	2-3/16	4-1/2	9-3/4	R.F.	24.0
12	2030842	7/8	2.500	2-5/16	2-3/16	4-1/2	10-1/4	R.F.	24.0
12	2023553	7/8	2.750	2-1/2	2-3/8	4-1/2	10-1/4	R.F.	28.0
12	62283	7/8	2.998	2-3/16	2-3/16	4-1/2	10-1/4	R.F.	24.0
12	4016594	7/8	3.000	1-3/4	1-5/8	4-1/2	10-1/4	R.F.	23.0
12	2030845	1	2.500	2-5/16	2-3/16	4	9-3/8	R.F.	24.0
12	2023551	1-1/8	2.750	2-1/2	2-3/8	4-1/2	9-3/8	R.F.	24.0
13	33653	3/8	2.500	1-1/2	1-1/8	3-1/2	11-5/8	R.F.	14.0
13	50704	1/2	2.500	1-1/2	1-1/8	3-1/2	11-5/8	R.F.	14.0
14	2023249	5/8	1.876	1-3/4	1-5/8	3-1/4	12-1/8	R.F.	20.0
14	2023243	3/4	1.876	1-3/4	1-5/8	3-1/4	11-3/4	R.F.	20.0
14	2023250	7/8	1.876	1-3/4	1-5/8	3-1/4	12-1/4	R.F.	20.0
14	2023567	7/8	2.750	2-1/2	2-3/8	4-1/2	12-1/4	R.F.	28.0
14	2023570	1	2.750	2-1/2	2-3/8	4-1/2	11-3/8	R.F.	28.0
14	2023564	1-1/8	2.750	2-1/2	2-3/8	4-1/2	11-3/8	R.F.	28.0
14	* 52720	1/2	4.250	2-1/2	1-3/8	5-1/16	12-5/8	D.I.	15.0
14	4013098	5/8	2.500	1-3/4	1-5/8	4-1/2	12-1/8	R.F.	31.0
14	4013187	5/8	2.375	1-3/4	1-5/8	4-1/2	12-1/8	R.F.	30.0
14	2029220	5/8	4.329	2-3/16	2-1/16	5-3/4	12-1/8	R.F.	30.0
14	4013196	3/4	2.375	1-3/4	1-5/8	4-1/2	11-3/4	R.F.	30.0
14	4013105	3/4	2.500	1-3/4	1-5/8	4-1/2	11-3/4	R.F.	31.0
14	4016503	3/4	3.250	2-5/16	2-3/16	5-1/2	11-3/4	R.F.	34.0
14	2029222	3/4	4.329	2-3/16	2-1/16	5-3/4	11-3/4	R.F.	32.0

McKissick Sheaves

McKissick® Roll-Forged sheaves highlighted above in bold italic are available with reduced lead times due to our advanced manufacturing process.

*Without flame hardening

Custom sheaves are available. See page 287 for ordering details.

"A" Nominal Outside Diameter (in)	Stock Number	Wire Line Size (in)	"D" Bore Size (in)	Hub Width (in)	Rim Width (in)	"C" Nominal Hub Outside Diameter (in)	"B" Nominal Tread Diameter (in)	Material	Approx. Weight (lb)
14	4013114	7/8	2.500	1-3/4	1-5/8	4-1/2	12-1/4	R.F.	30.0
14	52695	7/8	2.500	2-5/16	2-1/8	4-1/2	12-1/4	R.F.	45.0
16	4010000	1/2	4.248	2-3/4	2-3/8	5-3/4	14-1/4	R.F.	44.0
16	4010046	3/4	4.248	2-3/4	2-1/2	5-3/4	13-3/8	R.F.	25.0
16	4010171	7/8	2.998	2-3/16	2-3/16	4-1/2	12-15/16	R.F.	35.0
16	4013294	7/8	3.000	2-5/16	2-3/16	4-1/2	12-15/16	R.F.	47.0
16	4013258	7/8	3.249	2-5/16	2-3/16	4-1/2	12-15/16	R.F.	47.0
16	4010126	1	4.248	2-3/4	2-1/2	5-3/4	13-3/8	R.F.	42.0
17	62559	5/8	4.722	2-3/4	2-1/2	6-1/2	15	R.F.	52.0
18	2026599	3/4	4.248	2-3/4	2-3/16	6-1/2	16	R.F.	54.0
18	4010493	7/8	3.499	2-5/16	2-3/16	5-1/2	14-15/16	R.F.	64.0
18	2029269	7/8	6.100	2-7/8	2-5/8	8	14-15/16	R.F.	86.0
18	4013490	1	3.250	2-5/16	2-3/16	5-1/2	14-7/8	R.F.	53.0
18	4013524	1	3.499	2-5/16	2-3/16	5-1/2	14-7/8	R.F.	64.0
18	2023608	1	4.500	3	2-3/4	6-1/2	15-1/8	R.F.	60.0
18	2023602	1-1/8	4.500	3	2-3/4	6-1/2	15-1/8	R.F.	60.0
20	*4014024	5/16	4.248	2-3/4	1-3/8	5-3/4	18-7/8	R.F.	45.0
20	4010616	3/4	3.500	2-5/16	2-3/16	5-1/2	18	R.F.	66.0
20	4010885	3/4	4.248	2-3/4	2-1/8	6-1/2	18	R.F.	80.0
20	2029300	7/8	6.100	2-7/8	2-5/8	8	16-15/16	R.F.	70.0
20	4010634	1	3.500	2-5/16	2-3/16	5-1/2	16-1/2	R.F.	81.0
20	4013613	1	3.749	2-5/16	2-3/16	5-1/2	16-1/2	R.F.	76.00
20	2029304	1	6.100	2-7/8	2-5/8	8	16-1/2	R.F.	80.0
20	4010625	7/8	3.500	2-5/16	2-3/16	5-1/2	16-15/16	R.F.	74.0
20	4010901	1	4.248	2-3/4	2-1/8	6-1/2	16-1/2	R.F.	80.0
24	4012749	9/16	6.498	3-3/8	3-1/8	8	22	R.F.	148
24	*4014408	5/8	4.722	2-3/4	1-1/2	6-1/2	21-3/4	R.F.	120
24	2026108	7/8	6.498	3-3/8	3-1/8	8	20-7/8	R.F.	128
24	4011385	1	2.999	2-1/2	2-3/8	4-1/2	21-1/8	R.F.	125
24	4011214	1	4.500	3	2-3/4	6-1/2	21-1/8	R.F.	135
24	4012785	1	6.100	2-7/8	2-5/8	8	21-1/8	R.F.	130
24	2025931	1	6.498	3-3/8	3-1/8	8	21-1/8	R.F.	124
24	4011223	1-1/8	4.500	3	2-3/4	6-1/2	20-1/16	R.F.	130
24	2026646	1-1/8	4.722	2-3/4	2-3/4	6-1/2	20-1/16	R.F.	127
24	4012794	1-1/8	6.100	2-7/8	2-5/8	8	20-1/16	R.F.	120
24	2029333	1-1/8	6.498	3-3/8	3-1/8	8	20-1/16	R.F.	132
24	4011410	1-1/2	6.498	3-3/8	3-1/8	8-1/4	20	R.F.	186
30	2026302	7/8	6.498	3-3/8	3-1/8	8	27	R.F.	187
30	2029351	1	6.498	3-3/8	3-1/8	8	27	R.F.	187
30	2029375	1	7.873	3-1/2	3-1/8	9-1/2	27	R.F.	255
30	2029364	1-1/8	6.498	3-3/8	3-1/8	8	27	R.F.	187
30	2029378	1-1/8	7.873	3-1/2	3-1/8	9-1/2	26-3/8	R.F.	221
30	2029382	1-1/4	7.873	3-1/2	3-1/8	9-1/2	26-3/8	R.F.	225
30	4011839	1-1/2	7.873	3-1/2	3-1/8	9-1/2	26	R.F.	244
36	4012222	1	8.873	3-5/8	3-1/4	11	31-1/4	R.F.	353
36	4012160	1-1/8	6.498	3-3/8	3-1/8	8-1/4	32-1/4	R.F.	341
36	2027080	1-1/8	8.873	3-5/8	3-1/4	11	32-1/4	R.F.	308
36	2027967	1-1/4	7.873	3-1/2	3-1/4	9-1/2	32-1/4	R.F.	340
36	2026695	1-1/4	8.873	3-5/8	3-1/4	11	32-1/4	R.F.	359
36	4012730	1-1/2	7.873	3-1/2	3-1/4	9-1/2	32	R.F.	302
42	4015844	1-1/8	8.873	3-5/8	3-1/4	11	38-1/2	R.F.	460
42	4015728	1-1/8	10.873	3-5/8	3-3/8	12-1/2	38-1/2	R.F.	443
42	4015853	1-1/4	8.873	3-5/8	3-1/4	11	38-3/8	R.F.	460
42	4015719	1-1/4	10.873	3-5/8	3-3/8	12-1/2	38-3/8	R.F.	443
48	4016736	2	13.873	4-1/8	3-3/4	17	42	R.F.	735
50	4016745	1-1/4	13.873	4-1/8	3-3/4	17	46-1/4	R.F.	675
55	4016282	1-1/8	6.498	3-3/8	3	8-1/4	51-1/8	R.F.	537
60	4016754	1-3/8	13.873	4-1/8	3-5/8	17	55-1/2	R.F.	937
60	4016763	1-1/2		4-1/8	3-5/8	17	55-3/8	R.F.	937
64	8060983	2	13.999	6	4-1/4	17	58	R.F.	1145
72	4016772	1-3/4	15.498	4-1/8	3-3/4	19	67	R.F.	1790
78	2032626	2-1/2	16.620	6-13/16	4-15/16	21	71-3/8	R.F./F.	2200

McKissick® Roll-Forged sheaves highlighted above in bold italic are available with reduced lead times due to our advanced manufacturing process.

*Without flame hardening groove

Custom sheaves are available. See page 287 for ordering details.

McKissick® Common Bore Sheaves

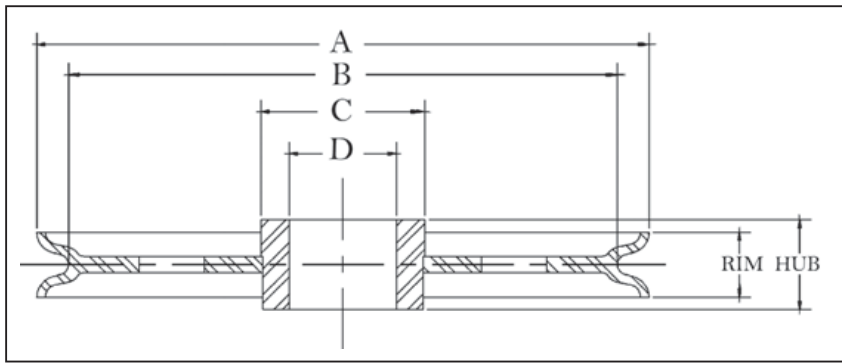

Common Bore Sheaves

- Roll-Forged sheaves are available in sizes up to 78" in diameter.
- Common Bore or Plain Bore are terms used when there is merely a hole bored in the center of the sheave.
- Common Bore Sheaves are machined for a running fit for the shaft size listed

"A" Nominal Outside Diameter (in)	Stock Number	Wire Line Size (in)	"D" Bore Size (in)	Hub Width (in)	Rim Width (in)	"C" Nominal Hub Outside Diameter (in)	"B" Nominal Tread Diameter (in)	Material	Approx. Weight (lb)
3	905051	3/16	3/8	25/32	3/4	1	2-3/8	P.M.	1.00
3	905079	3/16	1/2	25/32	3/4	1	2-3/8	P.M.	1.00
3	905097	3/16	5/8	25/32	3/4	1	2-3/8	P.M.	1.00
3	905024	1/4	3/8	1/2	1/2	1	2-5/8	P.M.	.75
3	905042	1/4	1/2	1/2	1/2	1	2-5/8	P.M.	.75
3	15410	3/8	3/8	25/32	3/4	1	2-3/8	P.M.	1.00
3	905088	3/8	1/2	25/32	3/4	1	2-3/8	P.M.	1.00
3	905104	3/8	5/8	25/32	3/4	1	2-3/8	P.M.	.60
4	905113	3/16	1/2	3/4	5/8	1-3/8	3-1/2	P.M.	1.00
4	905131	3/16	5/8	3/4	5/8	1-3/8	3-1/2	P.M.	1.00
4	905122	5/16	1/2	3/4	5/8	1-3/8	3-1/2	P.M.	1.00
4	905140	5/16	5/8	3/4	5/8	1-3/8	3-1/2	P.M.	1.00
4	905168	3/8	1/2	13/16	3/4	1-1/2	3-1/4	P.M.	1.25
4	905186	3/8	5/8	13/16	3/4	1-1/2	3-1/4	P.M.	1.25
4	905202	3/8	3/4	13/16	3/4	1-1/2	3-1/4	P.M.	1.25
4	905220	1/2	1/2	1-1/16	1	1-5/8	3-3/16	P.M.	1.50
4	905248	1/2	5/8	1-1/16	1	1-5/8	3-3/16	P.M.	1.50
4	905266	1/2	3/4	1-1/16	1	1-5/8	3-3/16	P.M.	1.50
5	905275	3/16	5/8	15/16	7/8	2-1/4	4-1/4	P.M.	2.25
5	905293	3/16	3/4	15/16	7/8	2-1/4	4-1/4	P.M.	2.25
5	905284	3/8	5/8	15/16	7/8	2-1/4	4-1/4	P.M.	2.75
5	905300	3/8	3/4	15/16	7/8	2-1/4	4-1/4	P.M.	2.25
5	905328	1/2	5/8	1-1/16	1	2-1/4	4	P.M.	2.50
5	905364	1/2	5/8	1-3/16	1-1/8	2-1/4	4	D.I.	4.00
5	905346	1/2	3/4	1-1/16	1	2-1/4	4	P.M.	2.50
5	905382	1/2	3/4	1-3/16	1-1/8	2-1/4	4	D.I.	4.00
5	905408	1/2	7/8	1-3/16	1-1/8	2-1/4	4	D.I.	4.00
6	905426	3/8	1/2	13/16	3/4	1-7/8	5	D.I.	2.50
6	905480	3/8	1/2	1-1/16	1	1-7/8	5	D.I.	2.50
6	905462	3/8	3/4	13/16	3/4	1-7/8	5	P.M.	2.50
6	905523	3/8	3/4	1-1/16	1	1-7/8	5	P.M.	4.16
6	909020	1/2	7/8	1-1/16	1	1-7/8	4-7/8	P.M.	3.75
6	909066	5/8	3/4	1-5/16	1-1/4	1-7/8	4-3/4	P.M.	3.75
6	909084	5/8	7/8	1-5/16	1-1/4	1-7/8	4-3/4	P.M.	3.75
6	909100	5/8	1	1-5/16	1-1/4	1-7/8	4-3/4	P.M.	3.75
6	909164	3/4	1	1-9/16	1-1/2	3	4-5/8	P.M.	6.75
6-3/4	905694	1/4	3/4	1-3/16	1-1/8	2	5-7/8	D.I.	5.00
6-3/4	905710	1/4	1	1-3/16	1-1/8	2	5-7/8	D.I.	5.00
6-3/4	905701	3/8	3/4	1-3/16	1-1/8	2	5-7/8	D.I.	5.00
6-3/4	905729	3/8	1	1-3/16	1-1/8	2	5-7/8	D.I.	5.00
7	905621	1/2	3/4	1-1/16	1	2	5-1/2	D.I.	5.25
7	905649	1/2	7/8	1-1/16	1	2	5-1/2	D.I.	5.25
8	905747	1/2	3/4	1-1/8	1	2-3/8	6-7/8	D.I.	5.00
8	905765	1/2	7/8	1-1/8	1	2-3/8	6-7/8	D.I.	5.00
8	905783	1/2	1	1-1/8	1	2-3/8	6-7/8	D.I.	8.50

McKissick Sheaves

Custom sheaves are available. See page 287 for ordering details.

"A" Nominal Outside Diameter (in)	Stock Number	Wire Line Size (in)	"D" Bore Size (in)	Hub Width (in)	Rim Width (in)	"C" Nominal Hub Outside Diameter (in)	"B" Nominal Tread Diameter (in)	Material	Approx. Weight (lb)
8	905809	5/8	3/4	1-3/8	1-1/4	2	6-1/2	D.I.	6.00
8	905827	5/8	7/8	1-3/8	1-1/4	2	6-1/2	D.I.	6.75
8	909306	5/8	7/8	1-3/8	1-1/4	2-1/2	6-5/8	D.I.	8.50
8	905845	5/8	1	1-3/8	1-1/4	2	6-1/2	D.I.	6.75
8	909324	5/8	1	1-3/8	1-1/4	2-1/2	6-5/8	D.I.	8.50
8	909342	5/8	1-1/8	1-3/8	1-1/4	2-1/2	6-5/8	D.I.	8.50
8	909360	5/8	1-1/4	1-3/8	1-1/4	2-1/2	6-5/8	D.I.	8.50
8	909388	5/8	1-1/2	1-3/8	1-1/4	2-1/2	6-5/8	D.I.	8.50
10	905925	1/2	7/8	1-1/8	1	2-7/8	8-3/4	D.I.	10.0
10	905943	1/2	1	1-1/8	1	2-7/8	8-3/4	D.I.	10.0
10	905961	5/8	3/4	1-3/8	1-1/4	2	8-1/2	D.I.	9.25
10	905989	5/8	7/8	1-3/8	1-1/4	2	8-1/2	D.I.	9.25
10	909681	5/8	7/8	1-3/8	1-1/4	3	8-1/2	D.I.	13.5
10	906005	5/8	1	1-3/8	1-1/4	3	8-1/2	D.I.	9.25
10	909761	5/8	1-1/2	1-3/8	1-1/4	3	8-1/2	D.I.	13.5
12	906041	1/2	1	1-1/8	1	4	10-5/8	D.I.	16.5
12	906087	1/2	1-1/4	1-1/8	1	4	10-5/8	D.I.	16.5
12	906121	3/4	1	1-5/8	1-1/2	2-3/4	10-1/4	D.I.	18.3
12	910107	3/4	1	1-5/8	1-1/2	5-1/4	10-1/4	D.I.	25.5
12	906149	3/4	1-1/8	1-5/8	1-1/2	2-3/4	10-1/4	D.I.	18.3
12	910125	3/4	1-1/8	1-5/8	1-1/2	5-1/4	10-1/4	D.I.	25.5
12	906167	3/4	1-1/4	1-5/8	1-1/2	2-3/4	10-1/4	D.I.	18.3
12	910143	3/4	1-1/4	1-5/8	1-1/2	5-1/4	10-1/4	D.I.	25.5
12	910161	3/4	1-1/2	1-5/8	1-1/2	5-1/4	10-1/4	D.I.	25.5
12	906229	7/8	1-1/4	2	1-3/4	3-3/4	10	D.I.	20.3
12	906247	7/8	1-1/2	2	1-3/4	3-3/4	10	D.I.	20.3
14	*906283	3/4	1-1/8	1-5/8	1-1/2	3-1/4	12-1/4	C.I.	26.5
14	*906309	3/4	1-1/4	1-5/8	1-1/2	3-1/4	12-1/4	C.I.	26.5
14	*910456	7/8	1-1/2	1-5/8	1-1/2	3-1/2	12-1/8	C.I.	34.0
14	*910447	7/8	1-1/4	1-5/8	1-1/2	3-1/2	12-1/8	C.I.	34.0
16	910713	1	2	2	1-3/4	4-1/2	13-5/8	R.F.	47.0
16	910697	1	1-1/2	2	1-3/4	4-1/2	13-5/8	R.F.	47.0
18	910820	1	2	2	1-7/8	4	14-7/8	R.F.	62.0

Material: B.S.=Bar Steel, C.I.=Cast Iron, F.S.=Forged Steel, D.I.=Ductile Iron, C.S.=Cast Steel, P.M.=Powdered Metal, R.F.=Roll-Forged.
 McKissick® Roll-Forged sheaves highlighted above in bold italic are available with reduced lead times due to our advanced manufacturing process.
 *Without flame hardening groove

Custom sheaves are available. See page 287 for ordering details.

McKissick® Bronze Bushed Sheaves

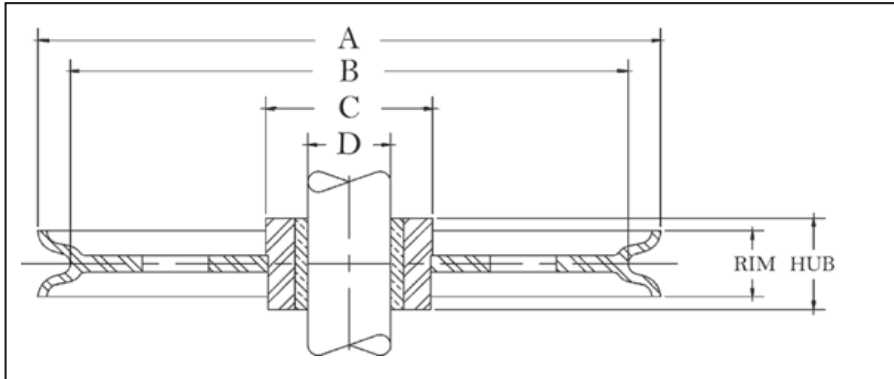

Bronze Bushed Sheaves

- Roll-Forged sheaves are available in sizes up to 78" in diameter.
- McKissick® Bronze Bushed Sheaves are equipped with S.A.E. 660 Bronze Bushings for cold finished shafts with "Figure 8" oil groove.
- For sizes not listed, McKissick Finished Bore Sheaves can be equipped with bronze bushings at an optional charge.

"A" Nominal Outside Diameter (in)	Stock Number	Wire Line Size (in)	"D" Shaft Size (in)	Hub Width (in)	Rim Width (in)	"C" Nominal Hub Outside Diameter (in)	"B" Nominal Tread Diameter (in)	Material	Approx. Weight (lb)
2-1/4	907004	1/4	3/8*	5/8	9/16	3/4	1-7/8	B.S.	.75
3	907059	3/16	3/8*	25/32	3/4	1	2-3/8	P.M.	1.00
3	907077	3/16	1/2*	25/32	3/4	1	2-3/8	P.M.	1.00
3	907095	3/16	5/8*	25/32	3/4	1	2-3/8	P.M.	1.00
3	907022	1/4	3/8*	1/2	1/2	1	2-5/8	P.M.	.75
3	907040	1/4	1/2*	1/2	1/2	1	2-5/8	P.M.	.75
3	460165	1/4	1/2*	1-5/16	1-3/16	1-1/8	2-1/16	B.S.	1.00
3	2030896	5/16	3/4	1	7/8	1-3/4	2-1/4	P.M.	1.50
3	907068	3/8	3/8*	3/4	3/4	1	2-3/8	P.M.	1.00
3	916101	3/8	3/8*	25/32	3/4	1-1/2	2-3/8	B.S.	1.00
3	907086	3/8	1/2*	3/4	3/4	1	2-3/8	P.M.	1.00
3	916110	3/8	1/2*	25/32	3/4	1-1/2	2-3/8	B.S.	1.00
3	460156	3/8	1/2*	1-5/16	1-3/16	1-1/8	2-1/16	B.S.	1.00
3	907102	3/8	5/8*	3/4	3/4	1	2-3/8	P.M.	1.00
3	2030895	3/8	3/4	1	7/8	1-3/4	2-1/4	P.M.	1.50
3	2023202	7/16	3/4	1	7/8	1-3/4	2-1/4	P.M.	1.50
3	916129	1/2	3/8*	1-1/4	1-1/8	1-7/8	2	B.S.	1.33
3	916138	1/2	1/2*	1-1/4	1-1/8	1-7/8	2	B.S.	1.50
4	460290	1/8	1	1	7/8	2	3-1/8	B.S.	2.00
4	907111	3/16	1/2*	3/4	5/8	1-3/8	3-1/2	P.M.	1.00
4	907139	3/16	5/8*	3/4	5/8	1-3/8	3-1/2	P.M.	1.00
4	916147	1/4	1/2*	13/16	3/4	2	3-1/4	B.S.	1.50
4	916165	1/4	3/4*	13/16	3/4	2	3-1/4	B.S.	1.50
4	460307	1/4	1	1	7/8	2	3-1/8	B.S.	2.00
4	907120	5/16	1/2*	3/4	5/8	1-3/8	3-1/2	P.M.	1.00
4	907148	5/16	5/8*	3/4	5/8	1-3/8	3-1/2	P.M.	1.00
4	907166	3/8	1/2*	13/16	3/4	1-1/2	3-1/4	P.M.	1.25
4	916156	3/8	1/2*	13/16	3/4	2	3-1/4	B.S.	1.50
4	907184	3/8	5/8*	13/16	3/4	1-1/2	3-1/4	P.M.	1.40
4	907200	3/8	3/4*	13/16	3/4	1-1/2	3-1/4	P.M.	1.25
4	460316	3/8	1	1	7/8	2	3-1/8	B.S.	2.00
4	907228	1/2	1/2*	1-1/16	1	1-5/8	3-3/16	P.M.	1.50
4	916192	1/2	1/2*	1-1/8	1	1-5/8	3-3/16	BS.	2.00
4	907246	1/2	5/8*	1-1/16	1	1-5/8	3-3/16	P.M.	1.50
4	907264	1/2	3/4*	1-1/16	1	1-5/8	3-3/16	P.M.	1.50
4	2028640	3/8	3/4*	13/16	3/4	2	3-1/4	B.S.	1.50
4-1/8	2023186	3/8	1	1-1/2	1-3/8	2	3	F.S.	3.50
4-1/8	2029618	1/2	1	1-1/2	1-3/8	2	3	F.S.	3.50
4-1/8	2023188	5/8	1	1-1/2	1-3/8	2	3	F.S.	3.50
4-1/4	460450	3/8	5/8*	1-3/16	15/16	2-1/8	3-3/8	B.S.	2.40
4-1/4	460441	1/2	5/8*	1-3/16	15/16	2-1/8	3-3/8	B.S.	2.40
4-3/4	460575	5/16	5/8	1-9/16	1-3/8	1-1/2	3-5/8	D.I.	3.50
4-3/4	460584	3/8	5/8	1-9/16	1-3/8	1-1/2	3-5/8	D.I.	3.50
4-3/4	460593	1/2	5/8	1-9/16	1-3/8	1-1/2	3-5/8	D.I.	3.50

*Self Lubricating Bushing. Custom sheaves are available. See page 287 for ordering details.

McKissick® Bronze Bushed Sheaves

"A" Nominal Outside Diameter (in)	Stock Number	Wire Line Size (in)	"D" Shaft Size (in)	Hub Width (in)	Rim Width (in)	"C" Nominal Hub Outside Diameter (in)	"B" Nominal Tread Diameter (in)	Material	Approx. Weight (lb)
4-7/8	460478	3/8	1-1/4	1-1/4	1-1/8	2-1/4	4-1/16	F.S.	3.60
4-7/8	2026414	1/2	1-1/4	1-1/4	1-1/8	2-1/4	4-1/16	F.S.	3.60
4-7/8	460469	5/8	1-1/4	1-1/4	1-1/8	2-1/4	4-1/16	F.S.	3.60
5	907273	3/16	5/8*	15/16	7/8	2-1/4	4-1/4	P.M.	2.25
5	907291	3/16	3/4*	15/16	7/8	2-1/4	4-1/4	P.M.	2.25
5	460511	5/16	3/4	1	7/8	1-1/2	4	F.S.	2.50
5	907282	3/8	5/8*	15/16	7/8	2-1/4	4-1/4	P.M.	2.75
5	907308	3/8	3/4*	15/16	7/8	2-1/4	4-1/4	P.M.	2.80
5	460520	3/8	3/4	1	7/8	1-1/2	4	F.S.	2.50
5	460539	7/16	3/4	1	7/8	1-1/2	4	F.S.	2.50
5	907326	1/2	5/8*	1-1/16	1	2-1/4	4	P.M.	2.50
5	907362	1/2	5/8*	1-3/16	1-1/8	2-1/4	4	D.I.	4.00
5	907344	1/2	3/4*	1-1/16	1	2-1/4	4	P.M.	2.50
5	907380	1/2	3/4*	1-3/16	1-1/8	2-1/4	4	D.I.	4.00
5	907406	1/2	7/8*	1-3/16	1-1/8	2-1/4	4	D.I.	4.00
5-1/4	460628	5/8	1	1-1/2	1-3/8	2-1/16	3-7/8	F.S.	4.00
5-1/4	460637	3/4	1	1-1/2	1-3/8	2-1/16	3-7/8	F.S.	4.00
5-7/8	2023129	5/8	1-1/2	1-3/4	1-5/8	2-1/2	4-3/8	F.S.	6.00
5-7/8	2023137	3/4	1-1/2	1-3/4	1-5/8	2-1/2	4-3/8	F.S.	6.00
5-7/8	2023135	7/8	1-1/2	1-3/4	1-5/8	2-1/2	4-3/8	F.S.	6.00
6	907424	3/8	1/2*	13/16	3/4	1-7/8	5	P.M.	2.50
6	907488	3/8	1/2*	1-1/16	1	1-7/8	5	P.M.	2.50
6	907442	3/8	5/8*	13/16	3/4	1-7/8	5	P.M.	2.50
6	907503	3/8	5/8*	1-1/16	1	1-7/8	5	P.M.	2.50
6	907460	3/8	3/4*	13/16	3/4	1-7/8	5	P.M.	2.50
6	907521	3/8	3/4*	1-1/16	1	1-7/8	5	P.M.	4.26
6	2026483	3/8	3/4*	1-1/16	1	2	5-1/8	F.S.	4.00
6	916245	3/8	7/8*	1-1/16	1	2	5-1/8	F.S.	4.00
6	2028641	3/8	1*	1-1/16	1	2	5-1/8	F.S.	4.00
6	460682	3/8	1-1/4	1-1/8	1	2-1/4	4-15/16	F.S.	3.70
6	907549	1/2	5/8*	1-3/16	1-1/8	1-7/8	4-7/8	P.M.	5.00
6	907567	1/2	3/4*	1-3/16	1-1/8	1-7/8	4-7/8	P.M.	4.72
6	913024	1/2	7/8*	1-1/16	1	1-7/8	4-7/8	P.M.	3.75
6	460879	1/2	1	1-1/2	1-1/4	3-1/8	4-3/4	B.S.	7.00
6	460673	1/2	1-1/4*	1-1/8	1	2-1/4	4-15/16	F.S.	3.63
6	2028048	1/2	1	1-1/16	1	1-7/8	4-7/8	P.M.	3.75
6	2026938	5/8	3/4*	1-1/16	1	2	5-1/8	F.S.	4.00
6	913060	5/8	3/4*	1-5/16	1-1/4	1-7/8	4-3/4	P.M.	3.75
6	916254	5/8	7/8*	1-1/16	1	2	5-1/8	F.S.	4.00
6	913088	5/8	7/8*	1-5/16	1-1/4	1-7/8	4-3/4	P.M.	5.00
6	2026822	5/8	1*	1-1/16	1	2	5-1/8	F.S.	4.00
6	913104	5/8	1*	1-5/16	1-1/4	1-7/8	4-3/4	P.M.	3.75
6	2023264	5/8	2	2-5/16	2-3/16	3-1/8	4-1/4	F.S.	9.50
6	460897	3/4	1	1-1/2	1-1/4	3-1/2	4-3/4	B.S.	7.00
6	913168	3/4	1	1-9/16	1-1/2	1-7/8	4-5/8	P.M.	6.75
6	2023260	3/4	2	2-5/16	2-3/16	3-1/8	4-1/4	F.S.	9.50
6	2023262	7/8	2	2-5/16	2-3/16	3-1/2	4-1/4	F.S.	9.50
6-3/4	907692	1/4	3/4*	1-3/16	1-1/8	2	5-7/8	D.I.	5.00
6-3/4	907718	1/4	1*	1-3/16	1-1/8	2	5-7/8	D.I.	5.00
6-3/4	907709	3/8	3/4*	1-3/16	1-1/8	2	5-7/8	D.I.	5.00
6-3/4	907727	3/8	1*	1-3/16	1-1/8	2	5-7/8	D.I.	5.00
7	461020	1/4	1-1/2	1-3/8	3/4	2-3/8	6-1/4	B.S.	6.20
7	461039	3/8	1-1/2	1-3/8	3/4	2-3/8	6-1/4	B.S.	6.20
7	907629	1/2	3/4*	1-1/16	1	2	5-5/8	D.I.	4.25
7	907647	1/2	7/8*	1-1/16	1	2	5-5/8	D.I.	4.25
7-1/2	460986	5/8	1	1-1/2	1-3/8	2-1/16	6-5/16	F.S.	7.50
7-1/2	460977	3/4	1	1-1/2	1-3/8	2-1/16	6-5/16	F.S.	7.50
7-5/8	461262	3/8	1	1-1/2	1-1/4	2-3/8	6-3/16	D.I.	7.00
7-5/8	461280	1/2	1	1-1/2	1-1/4	2-3/8	6-3/16	D.I.	7.00
7-5/8	461271	5/8	1	1-1/2	1-1/4	2-3/8	6-3/16	D.I.	7.00

*Self Lubricating Bushing.

Custom sheaves are available. See page 287 for ordering details.

McKissick® Bronze Bushed Sheaves

"A" Nominal Outside Diameter (in)	Stock Number	Wire Line Size (in)	"D" Shaft Size (in)	Hub Width (in)	Rim Width (in)	"C" Nominal Hub Outside Diameter (in)	"B" Nominal Tread Diameter (in)	Material	Approx. Weight (lb)
8	2023467	1	2-1/4	2-1/2	2-3/8	4-1/2	5-3/8	F.S.	18.0
8	2023463	1-1/8	2-1/4	2-1/2	2-3/8	4-1/2	5-3/8	F.S.	18.0
8	2023153	3/4	1-1/2	1-3/4	1-5/8	2-9/16	6-5/16	F.S.	10.0
8	907745	1/2	3/4*	1-1/8	1	2-3/8	6-7/8	D.I.	5.00
8	916487	1/2	3/4*	1-3/8	1-1/4	2	6-5/8	F.S.	7.00
8	907763	1/2	7/8*	1-1/8	1	2-3/8	6-7/8	D.I.	5.00
8	916502	1/2	7/8*	1-3/8	1-1/4	2	6-5/8	F.S.	7.00
8	907781	1/2	1*	1-1/8	1	2-3/8	6-7/8	D.I.	5.59
8	916520	1/2	1*	1-3/8	1-1/4	2	6-5/8	F.S.	7.00
8	2026841	1/2	1-1/8*	1-3/8	1-1/4	2	6-5/8	F.S.	7.00
8	2026844	1/2	1-1/4*	1-3/8	1-1/4	2	6-1/8	F.S.	7.00
8	461235	1/2	1-1/2	1-1/2	1-3/8	2-7/16	6-5/8	F.S.	7.00
8	2023145	1/2	1-1/2	1-3/4	1-5/8	2-9/16	6-5/16	F.S.	10.0
8	907807	5/8	3/4*	1-3/8	1-1/4	2	6-1/2	D.I.	6.75
8	913300	5/8	7/8*	1-3/8	1-1/4	2-1/2	6-5/8	D.I.	8.50
8	913328	5/8	1*	1-3/8	1-1/4	2-3/4	6-5/8	D.I.	7.20
8	913346	5/8	1-1/8*	1-3/8	1-1/4	2-1/2	6-5/8	D.I.	8.50
8	913364	5/8	1-1/4*	1-3/8	1-1/4	2-1/2	6-5/8	D.I.	8.50
8	913382	5/8	1-1/2*	1-3/8	1-1/4	2-1/2	6-5/8	D.I.	8.50
8	461244	5/8	1-1/2	1-1/2	1-3/8	2-7/16	6-1/8	F.S.	7.00
8	2023147	5/8	1-1/2	1-3/4	1-5/8	2-9/16	6-5/16	F.S.	10.0
8	461253	3/4	1-1/2	1-1/2	1-3/8	2-7/16	6	F.S.	7.00
8	2028227	3/4	2	2-5/16	2-1/8	3-1/4	6-1/8	F.S.	12.5
8	461397	3/4	2-3/4	2-5/16	2-3/16	3-3/4	6	R.F.	10.5
8	2023386	7/8	2	2-5/16	2-1/8	3-1/4	6-1/8	F.S.	12.5
8	461501	1-1/8	3-1/2	2-1/2	2-3/8	5	5-7/16	C.S.	15.0
9-7/8	462831	3/8	2-1/2	1-3/4	1-1/8	3-3/4	8-9/16	F.S.	14.0
9-7/8	462154	1/2	1*	1-1/2	1-3/8	3-1/4	8-1/2	F.S.	9.50
9-7/8	2023166	1/2	1-1/2	1-3/4	1-5/8	2-9/16	8-5/16	F.S.	14.5
9-7/8	462840	1/2	2-1/2	1-3/4	1-1/8	3-3/4	8-9/16	F.S.	14.0
9-7/8	462163	5/8	1*	1-1/2	1-3/8	3-1/4	8-1/2	F.S.	9.50
9-7/8	2023170	5/8	1-1/2	1-3/4	1-5/8	2-9/16	8-5/16	F.S.	14.5
9-7/8	2023174	3/4	1-1/2	1-3/4	1-5/8	2-9/16	8-5/16	F.S.	14.5
9-7/8	2023420	7/8	2	2-5/16	2-3/16	3-1/2	8-1/8	F.S.	15.0
9-7/8	2023428	1	2	2-5/16	2-3/16	3-1/2	8-1/8	F.S.	15.0
10	2026861	1-1/8	2-1/4	2-1/2	2-3/8	4-1/2	7-3/8	F.S.	27.0
10	2023785	1-1/8	3-1/2	2-1/2	2-3/8	5-3/4	7-3/8	F.S.	28.0
10	907923	1/2	7/8*	1-1/8	1	2-7/8	8-3/4	D.I.	10.0
10	907941	1/2	1*	1-1/8	1	2-7/8	8-3/4	D.I.	11.8
10	907969	5/8	3/4*	1-3/8	1-1/4	2	8-1/2	D.I.	9.25
10	916717	5/8	7/8*	1-3/8	1-1/4	2-3/4	8-1/2	F.S.	10.0
10	913685	5/8	7/8*	1-3/8	1-1/4	3	8-1/2	D.I.	13.5
10	908003	5/8	1*	1-3/8	1-1/4	2	8-1/2	D.I.	9.25
10	916726	5/8	1*	1-3/8	1-1/4	2-3/4	8-1/2	F.S.	14.0
10	2027291	5/8	1-1/4*	1-3/8	1-1/4	2-3/4	8-1/2	F.S.	14.0
10	913765	5/8	1-1/2*	1-3/8	1-1/4	3	8-1/2	D.I.	12.6
10	913863	3/4	1-1/2*	1-5/8	1-1/2	3-1/2	8-1/4	F.S.	16.0
10	916824	3/4	1-1/4*	1-5/8	1-1/2	3-1/2	7-3/4	F.S.	17.0
10	913845	3/4	1-1/4*	1-5/8	1-1/2	3-1/2	8-1/4	F.S.	16.0
10	916833	3/4	1-1/2*	1-5/8	1-1/2	3-1/4	7-3/4	F.S.	17.0
10	913807	3/4	1*	1-5/8	1-1/2	3-1/2	8-1/4	F.S.	16.0
11-7/8	462323	3/8	2-1/2	2-5/16	1	3-3/4	10-3/4	D.I.	11.2
12	2023227	5/8	1-1/2	1-3/4	1-5/8	3-1/4	10-1/4	F.S.	22.0
12	2023235	3/4	1-1/2	1-3/4	1-5/8	3-1/4	9-3/8	F.S.	22.0
12	2023252	7/8	1-1/2	1-3/4	1-5/8	3-1/4	10-1/4	F.S.	22.0
12	462564	5/8	2-1/2	1-3/4	1-5/8	4-1/2	10-2/3	R.F.	24.0
12	462573	3/4	2-1/2	1-3/4	1-5/8	4-1/2	9-3/8	R.F.	24.0
12	908049	1/2	1*	1-1/8	1	4	10-5/8	D.I.	16.5
12	908085	1/2	1-1/4*	1-1/8	1	4	10-5/8	D.I.	16.5
12	917002	5/8	1*	1-5/8	1-1/2	3-1/4	10-1/8	F.S.	18.0
12	917011	5/8	1-1/8*	1-5/8	1-1/2	3-1/4	10-1/8	F.S.	18.0
12	462387	5/8	2	2-5/16	2-3/16	4-1/2	10-1/8	R.F.	26.0
12	908129	3/4	1*	1-5/8	1-1/2	2-3/4	10-1/4	D.I.	18.3
12	908147	3/4	1-1/8*	1-5/8	1-1/2	2-3/4	10-1/4	D.I.	18.3
12	914121	3/4	1-1/8*	1-5/8	1-1/2	5-1/4	10-1/4	D.I.	25.5

McKissick Sheaves

McKissick® Roll-Forced™ sheaves highlighted above in bold italic are available with reduced lead times due to our advanced manufacturing process. *Self-lubricating bushing.

Custom sheaves are available. See page 287 for ordering details.

McKissick® Bronze Bushed Sheaves

"A" Nominal Outside Diameter (in)	Stock Number	Wire Line Size (in)	"D" Shaft Size (in)	Hub Width (in)	Rim Width (in)	"C" Nominal Hub Outside Diameter (in)	"B" Nominal Tread Diameter (in)	Material	Approx. Weight (lb)
12	908147	3/4	1-1/8*	1-5/8	1-1/2	2-3/4	10-1/4	D.I.	18.3
12	914121	3/4	1-1/8*	1-5/8	1-1/2	5-1/4	10-1/4	D.I.	25.5
12	914149	3/4	1-1/4	1-5/8	1-1/2	5-1/4	10-1/4	D.I.	25.5
12	914167	3/4	1-1/2*	1-5/8	1-1/2	5-1/4	10-1/4	D.I.	25.5
12	346593	3/4	2-1/4	2-5/16	2-3/16	4-1/2	9-3/4	R.F.	26.0
12	4104882	3/4	2-1/2	1-3/4	1-5/8	4-1/2	9-3/4	R.F.	25.0
12	462449	3/4	2	2-5/16	2-3/16	4-1/2	9-3/4	R.F.	26.0
12	4104917	3/4	2-1/2	2-5/16	2-3/16	4-1/2	9-3/4	R.F.	25.0
12	462485	3/4	3	3	1-7/8	5-1/2	9-3/8	R.F.	21.0
12	908227	7/8	1-1/4*	2	1-3/4	3-3/4	10	D.I.	20.3
12	908245	7/8	1-1/2*	2	1-3/4	3-3/4	10	D.I.	20.3
12	462458	7/8	2	2-5/16	2-3/16	4-1/2	10-1/4	R.F.	26.0
12	2023554	7/8	2-1/4	2-1/2	2-3/8	4-1/2	9-3/8	R.F.	28.0
12	4104891	7/8	2-1/2	1-3/4	1-5/8	4-1/2	10-1/4	R.F.	25.0
12	462467	1	2	2-5/16	2-3/16	4	10	R.F.	26.0
12	2023552	1-1/8	2-1/4	2-1/2	2-3/8	4-1/2	9-3/8	R.F.	26.0
13	462779	3/8	2	1-1/2	1-1/8	3-1/2	11-5/8	R.F.	14.0
13	462788	1/2	2	1-1/2	1-1/8	3-1/2	11-5/8	R.F.	14.0
14	463625	5/8	1-1/2	1-3/4	1-5/8	3-1/4	12-1/8	R.F.	20.0
14	463634	3/4	1-1/2	1-3/4	1-5/8	3-1/4	11-3/8	R.F.	20.0
14	463643	7/8	1-1/2	1-3/4	1-5/8	3-1/4	11-3/8	R.F.	20.0
14	463448	7/8	2-1/4	2-1/2	2-3/8	4-1/2	12-1/4	R.F.	28.0
14	463457	1	2-1/4	2-1/2	2-3/8	4-1/2	11-3/8	R.F.	28.0
14	463466	1-1/8	2-1/4	2-1/2	2-3/8	4-1/2	11-3/8	R.F.	28.0
14	**463518	1/2	3-3/4	2-1/2	1-3/8	5-1/16	12-5/8	R.F.	15.0
14	4103552	5/8	2	1-3/4	1-5/8	4-1/2	12-1/8	R.F.	29.2
14	**908281	3/4	1-1/8*	1-5/8	1-7/16	3-1/4	12-1/4	C.I.	26.5
14	**908307	3/4	1-1/4*	1-5/8	1-1/2	3-1/4	12-1/4	C.I.	26.5
14	917173	3/4	1-1/4*	1-5/8	1-1/2	4	12	R.F.	26.5
14	917191	3/4	1-1/2*	1-5/8	1-1/2	3-1/4	11-3/4	R.F.	26.5
14	4103632	3/4	2	1-3/4	1-5/8	4-1/2	11-3/4	R.F.	30.0
14	4104828	3/4	2-3/4	2-5/16	2-3/16	5-1/2	11-3/4	R.F.	35.0
14	917182	7/8	1-1/4*	1-5/8	1-1/2	4	12	R.F.	26.5
14	917208	7/8	1-1/2*	1-5/8	1-1/2	4	12	R.F.	26.5
14	463484	7/8	2	2-5/16	2-1/8	4-1/2	11-3/8	R.F.	28.0
14	4103641	7/8	2	1-3/4	1-5/8	4-1/2	12-1/4	R.F.	31.0
16	4101395	1/2	3-1/2	2-3/4	2-1/2	5-3/4	14-1/4	R.F.	54.0
16	4100047	3/4	3-1/2	2-3/4	2-1/2	5-3/4	13-3/8	R.F.	47.0
16	4100109	3/4	3-3/4	2-3/4	2-1/2	5-3/4	13-3/8	R.F.	42.0
16	4103703	7/8	2-1/2	2-5/16	2-3/16	4-1/2	12-15/16	R.F.	35.0
16	4105211	7/8	2-3/4	2-5/16	2-3/16	4-1/2	12-15/16	R.F.	42.0
16	917342	1	1-1/2*	2	1-3/4	4-1/4	13-1/4	R.F.	34.0
16	917360	1	2*	2	1-3/4	4-1/4	13-1/4	R.F.	34.0
16	4100127	1	3-3/4	2-3/4	2-1/2	5-3/4	13-1/4	R.F.	63.0
18	4105131	7/8	3	2-5/16	2-3/16	5-1/2	14-15/16	R.F.	52.0
18	4105195	7/8	5-1/2	2-7/8	2-5/8	8	14-15/16	R.F.	59.0
18	917468	1	1-1/2*	2	1-7/8	3-1/4	14-7/8	R.F.	55.0
18	917486	1	2*	2	1-7/8	4-1/2	14-7/8	R.F.	55.0
18	914826	1	2*	2	1-3/4	5-3/4	15-3/4	R.F.	62.0
18	4104052	1	2-3/4	2-5/16	2-3/16	5-1/2	14-7/8	R.F.	66.0
18	4105140	1	3	2-5/16	2-3/16	5-1/2	14-7/8	R.F.	52.0
18	4100298	1	4	3	2-3/4	6-1/2	15-1/8	R.F.	81.0
18	4103348	1-1/8	4	3	2-3/4	6-1/2	15-1/8	R.F.	60.0
20	4100341	3/4	3	2-5/16	2-3/16	5-1/2	18	R.F.	68.0
20	4105239	3/4	3-3/4	2-3/4	2-1/8	6-1/2	18	R.F.	68.0
20	4100350	7/8	3	2-5/16	2-3/16	5-1/2	17-1/8	R.F.	45.0
20	4105266	7/8	5-1/2	2-7/8	2-5/8	8	16-15/16	R.F.	68.0
20	4100369	1	3	2-5/16	2-3/16	5-1/2	17-1/8	R.F.	80.2
20	4105328	1	3-1/4	2-5/16	2-3/16	5-1/2	17-1/8	R.F.	68.0
20	4105257	1	3-3/4	2-3/4	2-1/8	6-1/2	16-1/2	R.F.	68.0
20	4105275	1	5-1/2	2-7/8	2-5/8	8	17-1/8	R.F.	68.0
24	4105346	9/16	5-3/4	3-3/8	3-1/8	8	22	R.F.	113
24	4105355	7/8	5-3/4	3-3/8	3-1/8	8	21	R.F.	133
24	4100859	1	4	3	2-3/4	9	21-1/8	R.F.	140.0

McKissick® Roll-Forged™ sheaves highlighted above in bold italic are available with reduced lead times due to our advanced manufacturing process.

** Without Flame Harden groove.

*Self Lubricating Bushing.

McKissick® Bronze Bushed Sheaves

"A" Nominal Outside Diameter (in)	Stock Number	Wire Line Size (in)	"D" Shaft Size (in)	Hub Width (in)	Rim Width (in)	"C" Nominal Hub Outside Diameter (in)	"B" Nominal Tread Diameter (in)	Material	Approx. Weight (lb)
24	4105382	1	5-1/2	2-7/8	2-5/8	8	21-1/8	R.F.	130
24	4100868	1-1/8	4	3	2-3/4	6-1/2	20-1/16	R.F.	110
24	4105391	1-1/8	5-1/2	2-7/8	2-5/8	8	20-1/16	R.F.	134
24	4105373	1-1/8	5-3/4	3-3/8	3-1/8	8	20-1/16	R.F.	137
30	4105426	7/8	5-3/4	3-3/8	3-1/8	8	27	R.F.	203
30	4101215	7/8	6	3-1/2	3-1/8	8	27	R.F.	140
30	4105435	1	5-3/4	3-3/8	3-1/8	8	27	R.F.	203
30	4105453	1	7	3-1/2	3-1/8	9-1/2	27	R.F.	211
30	4105444	1-1/8	5-3/4	3-3/8	3-1/8	8	27	R.F.	203
30	4105462	1-1/8	7	3-1/2	3-1/8	9-1/2	26-3/8	R.F.	211
30	4105471	1-1/4	7	3-1/2	3-1/8	9-1/2	26-3/8	R.F.	211

Material: B.S.=Bar Steel, C.I.=Cast Iron, F.S.=Forged Steel, D.I.=Ductile Iron, C.S.=Cast Steel, P.M.=Powdered Metal, R.F.=Roll-Forged.

McKissick® Roller Bearing Sheaves

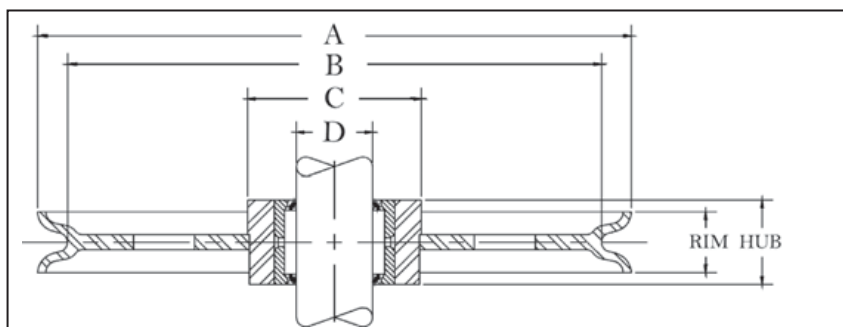

McKissick Sheaves

Roller Bearing Sheaves

- Roll-Forged sheaves are available in sizes up to 78" in diameter.
- McKissick® Roller Bearing Sheaves are designed to operate on shafts carburized to 60 Rockwell C and groove to +/- .0005 of the indicated shaft size. Some sizes are available with an optional inner race. Check with Crosby Sales for prices and correct shaft size.
- Application should provide for 1/32" running clearance over the hub width.
- For sizes not listed, McKissick Finished Bore Sheaves can be equipped with Roller Bearings at an optional charge.

"A" Nominal Outside Diameter (in)	Stock Number	Wire Line Size (in)	"D" Shaft Size (in)	Hub Width (in)	Rim Width (in)	"C" Nominal Hub Outside Diameter (in)	"B" Nominal Tread Diameter (in)	Material	Approx. Weight (lb)
4	472508	1/8	.997	1	7/8	2	3-1/8	B.S.	2.00
4	472517	1/4	.997	1	7/8	2	3-1/8	B.S.	2.00
4	472535	3/8	.997	1	7/8	2	3-1/8	B.S.	2.00
4	2025893	3/8	.997	1-1/2	1-3/8	2	3	F.S.	3.50
4	2028063	1/2	.997	1-1/2	1-3/8	2	3	F.S.	3.50
4	2025891	5/8	.997	1-1/2	1-3/8	2	3	F.S.	3.50
4-7/8	472768	3/8	1.247	1-1/4	1-1/8	2-1/4	4-1/16	F.S.	3.60
4-7/8	472777	1/2	1.247	1-1/4	1-1/8	2-1/4	4-1/16	F.S.	3.60
4-7/8	472786	5/8	1.247	1-1/4	1-1/8	2-1/4	4-1/16	F.S.	3.60
5-1/4	2026427	5/8	.997	1-1/2	1-3/8	2-1/16	3-7/8	F.S.	4.00
5-1/4	2026423	3/4	.997	1-1/2	1-3/8	2-1/16	3-7/8	F.S.	4.00
5-7/8	2023141	5/8	1.497	1-3/4	1-5/8	2-1/2	4-3/8	F.S.	6.00
5-7/8	2023143	3/4	1.497	1-3/4	1-5/8	2-1/2	4-3/8	F.S.	6.00
5-7/8	2023142	7/8	1.497	1-3/4	1-5/8	2-1/2	4-3/8	F.S.	6.00

McKissick® Roll-Forged sheaves highlighted above in bold italic are available with reduced lead times due to our advanced manufacturing process.

* Without Flame Harden groove.

McKissick® Roller Bearing Sheaves

"A" Nominal Outside Diameter (in)	Stock Number	Wire Line Size (in)	"D" Shaft Size (in)	Hub Width (in)	Rim Width (in)	"C" Nominal Hub Outside Diameter (in)	"B" Nominal Tread Diameter (in)	Material	Approx. Weight (lb)
6	472875	1/2	1.997	1-3/4	1-1/4	3-1/8	4-3/4	F.S.	7.00
7-1/2	2025898	5/8	.997	1-1/2	1-3/8	2-1/16	6-5/16	F.S.	7.50
7-1/2	2025892	3/4	.997	1-1/2	1-3/8	2-1/16	6-5/16	F.S.	7.50
7-5/8	473311	3/8	.997	1-1/2	1-1/4	2-3/8	6-3/16	D.I.	7.00
7-5/8	473320	1/2	.997	1-1/2	1-1/4	2-3/8	6-3/16	D.I.	7.00
7-5/8	473339	5/8	.997	1-1/2	1-1/4	2-3/8	6-3/16	D.I.	7.00
8	2023163	3/4	1.497	1-3/4	1-5/8	2-9/16	6-5/16	F.S.	10.0
8	2023155	1/2	1.497	1-3/4	1-5/8	2-9/16	6-5/16	F.S.	10.0
8	2023159	5/8	1.497	1-3/4	1-5/8	2-9/16	6-5/16	F.S.	10.0
8	2023404	3/4	1.997	2-5/16	2-1/8	3-1/4	6-1/8	F.S.	12.5
9-7/8	2026433	1/2	1.497	1-3/4	1-5/8	2-9/16	8-5/16	F.S.	14.5
9-7/8	2023179	5/8	1.497	1-3/4	1-5/8	2-9/16	8-5/16	F.S.	14.5
9-7/8	2023181	3/4	1.497	1-3/4	1-5/8	2-9/16	8-5/16	F.S.	14.5
9-7/8	2023436	3/4	1.997	2-5/16	2-3/16	3-1/2	8-1/8	F.S.	15.0
12	2023248	5/8	1.497	1-3/4	1-5/8	3-1/4	10-1/8	F.S.	18.0
12	2023236	3/4	1.497	1-3/4	1-5/8	3-1/4	9-3/4	F.S.	18.0
12	2026441	7/8	1.497	1-3/4	1-5/8	3-1/4	10-1/4	F.S.	18.0
12	474365	5/8	2.247	1-3/4	1-5/8	4-1/2	10-1/8	R.F.	16.0
12	474374	3/4	2.247	1-3/4	1-5/8	4-1/2	9-3/4	R.F.	16.0
14	2026445	5/8	1.497	1-3/4	1-5/8	3-1/4	12	R.F.	20.0
14	2026444	3/4	1.497	1-3/4	1-5/8	3-1/4	11-3/4	R.F.	20.0
14	474784	7/8	1.497	1-3/4	1-5/8	3-1/4	12-1/4	R.F.	20.0
14	4200563	5/8	1.997	1-3/4	1-5/8	4-1/2	12-1/8	R.F.	31.0
14	4200572	3/4	1.997	1-3/4	1-5/8	4-1/2	11-3/4	R.F.	31.0
16	4200705	7/8	2.497	2-5/16	2-3/16	4-1/2	12-15/16	R.F.	48.0
18	4201438	7/8	2.747	2-5/16	2-3/16	5-1/2	14-15/16	R.F.	42.7
18	4200867	1	2.747	2-5/16	2-3/16	5-1/2	14-7/8	R.F.	66.0
20	4200929	1	2.997	2-5/16	2-3/16	5-1/2	16-1/2	R.F.	77.0
24	4200117	1	2.247	2-1/2	2-3/8	5-1/2	21-1/8	R.F.	75.0

Material: B.S.=Bar Steel, C.I.=Cast Iron, F.S.=Forged Steel, D.I.=Ductile Iron, C.S.=Cast Steel, P.M.=Powdered Metal, R.F.=Roll-Forged.

McKissick® Roll-Forged sheaves highlighted above in bold italic are available with reduced lead times due to our advanced manufacturing process.

Custom sheaves are available. See page 287 for ordering details.

McKissick® Tapered Bearing Sheaves

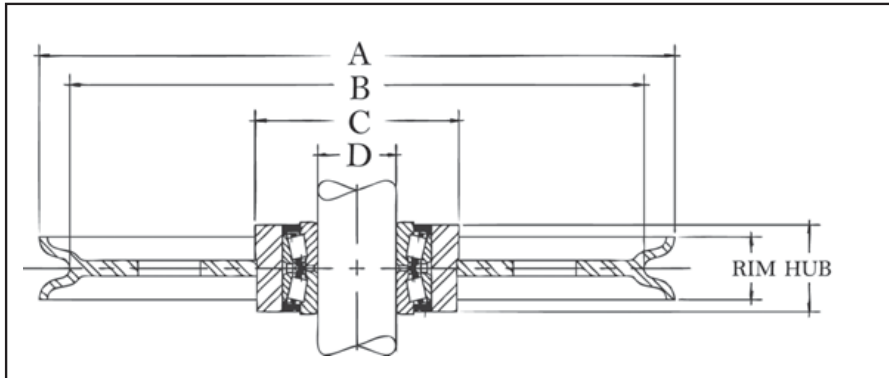

Tapered Bearing Sheaves

- Roll-Forged sheaves are available in sizes up to 78" in diameter.
- Tapered Bearing Sheaves are designed to operate on shafts machined to +/- .0005 of the indicated shaft size.
- Applications should provide for tightening separator plates against bearing cones to adjust and insure proper function of bearing.
- For sizes not listed, McKissick® Finished Bore Sheaves can be equipped with tapered bearing at an optional charge.

"A" Nominal Outside Diameter (in)	Stock Number	Wire Line Size (in)	"D" Shaft Size (in)	Hub Width (in)	Rim Width (in)	"C" Nominal Hub Outside Diameter (in)	"B" Nominal Tread Diameter (in)	Material	Approx. Weight (lb)
4-7/8	480269	3/8	.749	1-3/8	1-1/8	2-1/4	4-1/16	F.S.	3.60
7	480777	1/4	.749	1-3/8	3/4	2-3/8	6-1/4	B.S.	9.00
8	481017	1/2	.749	1-3/8	1-1/4	2-7/16	6-5/8	F.S.	7.00
8-1/2	481044	3/8	.749	1-3/8	1	2-3/4	7-1/2	D.I.	7.50
9-3/4	481295	3/8	1.499	2-5/16	1	3-3/4	8-3/4	F.S.	11.20
11-7/8	481552	1/4	1.499	2-5/16	1	3-3/4	10-3/4	D.I.	12.0
12	481455	3/4	1.499	2-5/16	2-3/16	4-1/2	9-3/4	R.F.	24.0
12	481446	7/8	1.499	2-5/16	2-3/16	4-1/2	10-1/4	R.F.	24.0
16	4302793	1/2	1.998	2-15/16	2-1/2	5-3/4	14-1/4	R.F.	50.0
16	4300599	3/4	1.998	2-15/16	2-1/2	5-3/4	13-3/8	R.F.	55.0
16	4300018	7/8	1.499	2-5/16	2-3/16	4-1/2	12-15/16	R.F.	37.0
16	4300054	1	1.998	2-15/16	2-1/2	5-3/4	13-3/8	R.F.	42.0
18	4300081	3/4	1.998	2-15/16	2-3/16	6-1/2	16	R.F.	40.0
20	*4302524	5/16	1.998	2-15/16	1-3/8	5-3/4	18-7/8	R.F.	54.0
20	4300161	3/4	1.998	2-15/16	2-1/8	6-1/2	18	R.F.	87.0
20	4300189	1	1.998	2-15/16	2-1/8	6-1/2	16-1/2	R.F.	84.0
24	4301721	9/16	4.248	3-1/2	3-1/8	8	22	R.F.	125
24	*4302720	5/8	2.755	2-15/16	1-1/2	6-1/2	21-3/4	R.F.	136
24	4300312	7/8	4.248	3-1/2	3-1/8	8	20-7/8	R.F.	125
24	4300321	1	4.248	3-1/2	3-1/8	7-5/8	21-1/8	R.F.	125
24	4300401	1-1/8	2.755	2-15/16	2-3/4	6-1/2	20-1/16	R.F.	80.0
24	4300330	1-1/8	4.248	3-1/2	3-1/8	8	20-1/16	R.F.	125
24	4300269	1-1/2	4.248	3-1/2	3-1/8	8-1/4	20	R.F.	125
30	4300483	7/8	4.248	3-1/2	3-1/8	8	27	R.F.	140
30	4300492	1	4.248	3-1/2	3-1/8	7-5/8	26.5	R.F.	210
30	4300526	1	5.624	3-11/16	3-1/8	9-1/2	27	R.F.	190
30	4300508	1-1/8	4.248	3-1/2	3-1/8	8	27	R.F.	140
30	4300535	1-1/8	5.624	3-11/16	3-1/8	9-1/2	26-3/8	R.F.	140
30	4300704	1-1/4	5.624	3-11/16	3-1/8	9-1/2	26-3/8	R.F.	140

* Without Flame Harden groove.

Material: B.S.=Bar Steel, C.I.=Cast Iron, F.S.=Forged Steel, D.I.=Ductile Iron, C.S.=Cast Steel, P.M.=Powdered Metal, R.F.=Roll-Forged.

McKissick® Roll-Forged sheaves highlighted above in bold italic are available with reduced lead times due to our advanced manufacturing process.

Custom sheaves are available. See page 287 for ordering details.

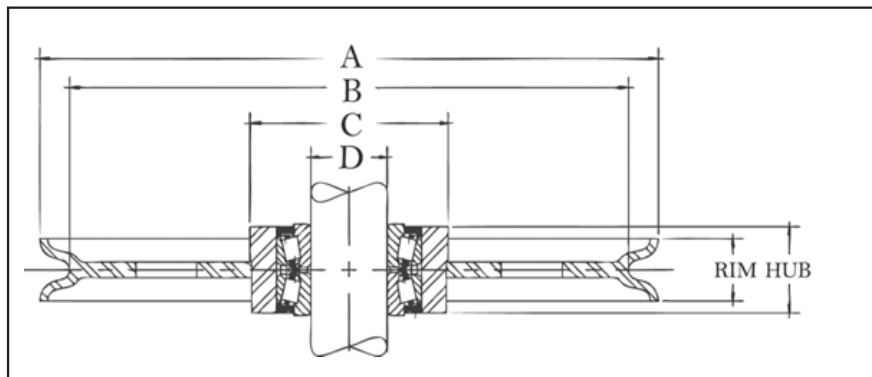

Plain Bore Oilfield Sheave

McKissick® Roll-Forged Sheaves are available in many configurations in order to meet various oilfield applications

- Roll-Forged sheaves are available in sizes up to 78" in diameter.
- Applications should provide for tightening separator plates against bearing cones to adjust and insure proper function of bearing.
- Each sheave in the table below has a machined bore sized to accept the respective bearing number shown.
- The sheaves are provided from the factory plain bore (the bearings are not included).

"A" Nominal Outside Diameter (in)	Stock Number	Wire Line Size (in)	Bore Information			Hub Width (in)	Rim Width (in)	"C" Nominal Hub Outside Diameter (in)	"B" Nominal Tread Diameter (in)	Material	Approx. Weight (lb)
			"D" Bore Size (in)	Bearing Info. (Bearing not Included)							
		Shaft Size (in)		Bearing or Equivalent Description							
20" Sheave											
20	2030311	9/16	4.722	2.756	NA-483-SW-472-D	2.750	2.750	6.500	17.62	R.F.	80
20	2029285	5/8	4.722	2.756	NA-483-SW-472-D	2.750	2.750	6.500	17.81	R.F.	75
24" Sheave											
24	2030941	9/16	6.498	4.250	NA56425-SW-56650D	3.375	3.125	8.00	21.62	R.F.	103
24	2030905	5/8	6.498	4.250	NA56425-SW-56650D	3.375	3.000	8.00	22.00	R.F.	117
24	2026108	7/8	6.498	4.250	NA56425-SW-56650D	3.375	3.125	8.00	20.94	R.F.	128
24	2025931	1	6.498	4.250	NA56425-SW-56650D	3.375	3.125	9.00	21.12	R.F.	125
24" Crown Sheave**											
24	2027885	9/16	6.498	4.250	NA56425-SW-56650D	3.375	3.125	8.00	21.62	R.F.	90
24	2027887	5/8	6.498	4.250	NA56425-SW-56650D	3.375	2.750	8.00	22.00	R.F.	80
24	2027880	7/8	6.498	4.250	NA56425-SW-56650D	3.375	3.125	8.00	20.94	R.F.	125
24	2023993	1	6.498	4.250	NA56425-SW-56650D	3.375	3.125	9.00	21.12	R.F.	110
30" Sheave											
30	2026299	1	6.498	4.250	NA56425-SW-56650D	3.375	3.125	8.50	26.50	R.F.	190
30	2026036	1-1/8	6.498	4.250	NA56425-SW-56650D	3.375	3.125	9.00	26.06	R.F.	230
30	2026230	1	7.873	5.625	NA48685-SW/48620	3.500	3.125	10.25	26.50	R.F.	255
30	2026003	1-1/8	7.873	5.625	NA48685-SW/48620	3.500	3.125	10.25	26.06	R.F.	255
30	2030906	1	8.873	6.500	NA46790-SW-46720	3.625	3.375	10.25	26.50	R.F.	185
30	2030907	1-1/8	8.873	6.500	NA46790-SW-46720	3.625	3.375	12.00	26.06	R.F.	265
30" Crown Sheave**											
30	2027941	1	6.498	4.250	NA56425-SW-56650D	3.375	3.125	9.00	26.50	R.F.	150
30	2027945	1-1/8	6.498	4.250	NA56425-SW-56650D	3.375	3.125	9.00	26.06	R.F.	200
30	2030274	1	7.873	5.625	NA48685-SW/48620	3.500	3.125	10.25	26.50	R.F.	161
30	2030260	1-1/8	7.873	5.625	NA48685-SW/48620	3.500	3.125	10.25	26.06	R.F.	218
36" Sheave											
36	2030942	1	7.873	5.625	NA48685-SW/48620	3.500	3.250	10.250	33.12	R.F.	350
36	2030908	1-1/8	7.873	5.625	NA48685-SW/48620	3.500	3.250	10.250	33.62	R.F.	350
36	2027967	1-1/4	7.873	5.625	NA48685-SW/48620	3.500	3.250	12.00	32.25	R.F.	320
36	2030943	1	8.873	6.500	NA46790-SW-46720	3.625	3.125	11.50	33.12	R.F.	353
36	2029390	1-1/8	8.873	6.500	NA46790-SW-46720	3.625	3.250	11.00	32.62	R.F.	300
36	2029392	1-1/4	8.873	6.500	NA46790-SW-46720	3.625	3.250	11.00	32.25	R.F.	300
36	2030944	1	10.873	8.000	LM241149NW/241110-D	3.625	3.125	14.00	33.12	R.F.	370
36	2030909	1-1/8	10.873	8.000	LM241149NW/241110-D	3.625	3.500	14.00	32.06	R.F.	358
36	2030945	1-1/4	10.873	8.000	LM241149NW/241110-D	3.625	3.375	14.00	32.25	R.F.	330
36" Crown Sheave**											
36	2030282	1	7.873	5.625	NA48685-SW/48620	3.50	3.25	10.25	33.12	R.F.	240
36	2030284	1 1/8	7.873	5.625	NA48685-SW/48620	3.50	3.25	10.25	32.62	R.F.	250

** Crown Sheaves contain lightening holes.

Custom sheaves are available. See page 287 for ordering details.

McKissick® Standard API 8C Oilfield Sheaves

"A" Nominal Outside Diameter (in)	Stock Number	Wire Line Size (in)	Bore Information			Hub Width (in)	Rim Width (in)	"C" Nominal Hub Outside Diameter (in)	"B" Nominal Tread Diameter (in)	Material	Approx. Weight (lb)
			"D" Bore Size (in)	Bearing Info. (Bearing not Included)							
				Shaft Size (in)	Bearing or Equivalent Description						
42" Sheave											
42	2030949	1-1/4	10.873	8.000	LM241149NW/241110-D	3.625	3.250	14.00	38.25	R.F.	460
42	2030950	1-1/8	12.873	9.250	NA8575SW-8520CD	4.500	3.500	16.00	38.62	R.F.	465
42	2030951	1-1/4	12.873	9.250	NA8575SW-8520CD	4.500	3.375	16.00	38.25	R.F.	475
44" Sheave											
44	2030952	1-1/8	10.873	8.000	LM241149NW/241110-D	3.625	3.375	14.00	40.06	R.F.	615
44	2030953	1-1/4	10.873	8.000	LM241149NW/241110-D	3.625	3.000	14.00	40.25	R.F.	545
48" Sheave											
48	2030954	1-1/8	10.873	8.000	LM241149NW/241110-D	3.625	3.250	14.00	44.62	R.F.	580
48	2030955	1-1/4	10.873	8.000	LM241149NW/241110-D	3.625	2.750	14.00	44.25	R.F.	512
48	2030956	1-1/4	13.686	9.999	LM249747NW/LM249710D	3.875	3.250	17.00	44.25	R.F.	640
50" Sheave											
50	2030938	1-1/4	10.873	8.000	LM241149NW/241110-D	3.625	3.375	14.00	46.25	R.F.	765
50	2030957	1-1/4	13.686	8.000	LM241149NW/241110-D	3.875	3.250	17.00	46.25	R.F.	765
50	2030958	1-3/8	13.686	9.999	LM249747NW/ LM249710D	3.875	3.750	17.00	45.62	R.F.	735
55" Sheave											
55	2030959	1-1/8	12.873	9.250	NA8575SW-8520CD	4.500	3.500	16.00	51.06	R.F.	890
55	2030960	1-1/4	12.873	9.250	NA8575SW-8520CD	4.500	3.375	16.00	51.25	R.F.	825
55	2030961	1-1/4	13.686	9.999	LM249747NW/ LM249710D	3.875	3.500	19.00	51.25	R.F.	588
60" Sheave											
60	2030879	1-1/4	13.686	9.999	LM249747NW/ LM249710D	3.875	3.25	17.00	56.25	R.F.	1095
60	2030880	1-3/8	13.873	10.500	LM251649NW/251610-D	4.125	3.625	19.00	55.88	R.F.	1175
60	2030881	1-3/8	15.498	12.000	L357049NW/L357010D	4.125	3.75	19.00	55.88	R.F.	1175
60	2030875	1-1/2	13.686	9.999	LM249747NW/ LM249710D	3.875	3.50	19.00	55.50	R.F.	1175
60	2030872	1-1/2	13.873	10.500	LM251649NW/251610-D	4.125	3.625	19.00	55.50	R.F.	1175
60	2030876	1-1/2	15.498	12.000	L357049NW/L357010D	4.125	3.50	19.00	55.50	R.F.	1165
60	2030877	1-5/8	15.498	12.000	L357049NW/L357010D	4.125	3.50	19.00	55.12	R.F.	1150

Custom sheaves are available. See page 287 for ordering details.

McKissick® manufactures special Roll-Forged Sheaves to meet the Specifications of AISE Standard Number 6.

- AISE Sheaves must meet specified criteria established by the Association of Iron and Steel Engineers for special use in electric overhead Traveling Cranes for Steel Mill Service.
- Other typical applications that may specify AISE sheaves:
 - Mobile Cranes
 - Portal Cranes
 - Power Shovels
 - Other equipment using Wirelinee

Typical AISE Sheave Rim Profile with Specified Dimensional Requirements

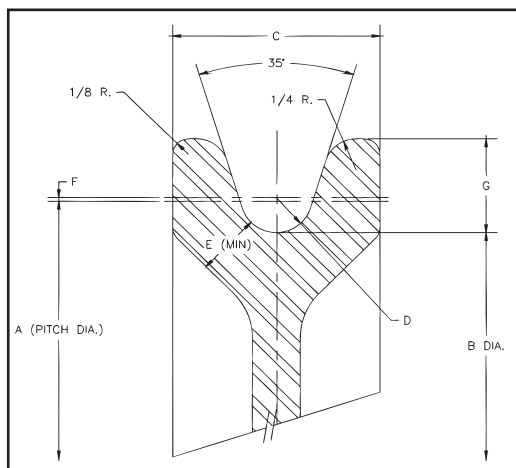

Sheave Wheel Contours							
Rope Diameter* (in)	Dimensions (in)						
	A	B	C	D	E	F	G
1/2	15	14-1/2	1-3/4	9/32	1/2	1/32	3/4
5/8	18-3/4	18-1/8	2	11/32	5/8	1/32	15/16
3/4	22-1/2	21-3/4	2-1/4	13/32	3/4	1/32	1-1/8
7/8	26-1/4	25-3/8	2-1/2	31/64	7/8	3/64	1-5/16
1	30	29	2-3/4	35/64	1	3/64	1-1/2
1-1/8	33-3/4	32-5/8	3	39/64	1-1/8	3/64	1-11/16
1-1/4	37-1/2	36-1/4	3-1/4	11/16	1-1/4	1/16	1-7/8
1-3/8	41-1/4	39-7/8	3-1/2	3/4	1-3/8	1/16	2-1/16
1-1/2	45	43-1/2	3-3/4	13/16	1-1/2	1/16	2-1/4

* Sheaves with other Wireline sizes are available upon request. Other pitch diameters available on application basis. Grooves are flame hardened to min. RC35 for 1/2" Wireline and larger.

For additional information concerning special AISE sheaves, contact:

In U.S.A. - Crosby's Special Engineered Product Group at 1-800-777-1555

In Canada - Crosby Canada at (877) 462-7672

In Europe - N.V. Crosby Europe at (+32) (0)15 75 71 25

McKissick® European Style 45° Metric Sheaves

Selecting your Sheave O.D. / Wireline Size Combinations

To ease the effort in choosing the proper standard McKissick® Roll-Forged sheave required for your application, we have simplified our product offering. The table below indicates the standard Sheave O.D. / Wireline sizes that are available.

How to Read the Table

- Cells outlined in RED represent the standard O.D. / Wireline combinations available with the Sheave Configurator program.

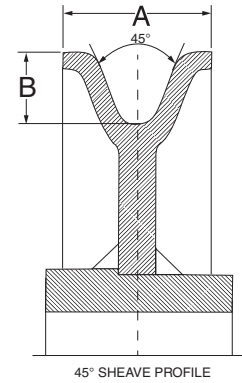

Sheave O.D. / Wireline Information

Wireline Size (mm)	Nominal Dimensions (mm)		Groove Radius (mm)		Sheave O.D. (mm)														
	A	B	MIN	MAX	280	300	320	350	400	450	500	520	550	600	630	650	700	800	
11	40	19	5.83	6.05															
12	40	18	6.36	6.60															
13	40	18	6.89	7.15															
11	40	19.5	5.38	6.05															
12	40	20.5	6.36	6.60															
13	40	19.5	6.89	7.15															
14	40	21	7.42	7.70															
15	40	21	7.95	8.25															
16	45	25	8.48	8.80															
17	45	25	9.01	9.35															
13	40	23	6.89	7.15															
14	40	22	7.42	7.70															
15	40	22	7.95	8.25															
15	45	25	7.95	8.25															
16	45	24	8.48	8.80															
17	45	24	9.01	9.35															
15	45	26	7.95	8.25															
16	45	25	8.48	8.80															
17	50	28	9.01	9.35															
18	50	27	9.54	9.90															
19	55	28.5	10.07	10.45															
20	55	25.5	10.60	11.00															
21	60	34	11.13	11.55															
22	60	33	11.66	12.10															
23	60	33	12.19	12.65															
19	55	31	10.07	10.45															
20	55	30	10.60	11.00															
21	55	30	11.13	11.55															
21	60	34	11.13	11.55															
22	60	33	11.66	12.10															
23	60	33	12.19	12.65															
21	60	34	11.13	11.55															
22	60	33	11.66	12.10															
23	60	33	12.19	12.65															
23	65	37	12.19	12.65															
24	65	36	12.72	13.20															
25	65	36	13.25	13.75															
26	70	39	13.78	14.30															
27	70	39	14.31	14.85															
23	65	37	12.19	12.65															
24	65	36	12.72	13.20															
25	65	36	13.25	13.75															
26	70	39	13.78	14.30															
27	75	43	14.31	14.85															
28	75	42	14.84	15.40															
29	75	42	15.37	15.95															
27	75	43	14.31	14.85															
28	75	43	14.84	15.40															
29	75	42	15.37	15.95															
28	80	47	14.84	15.40															
29	80	46	15.37	15.95															
30	80	45	15.90	16.50															
32	80	45	16.96	17.60															
30	90	50	15.90	16.50															
32	90	48	16.96	17.60															
34	90	48	18.02	18.70															
34	100	56	18.02	18.70															
36	100	54	19.08	19.80															
38	100	54	20.14	20.90															

McKissick Sheaves

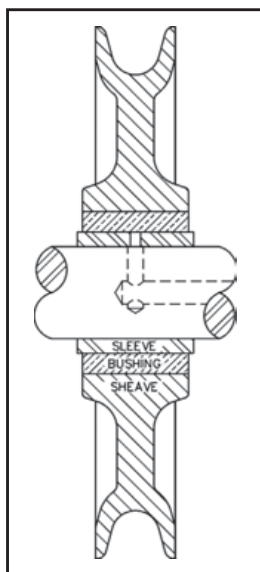

IRON SHEAVES FOR USE WITH MANILA ROPE BLOCKS

- 1101 – 1141
Common Iron Bushed
- 1102 – 1142
Roller Bushed
- 1103 – 1143
Bronze Bushed, Self-Lubricating

FOR REGULAR MANILA ROPE BLOCKS – OLD STYLE

Block Size	Stock No.			Manila Rope Size (in)	Sheave Size (in)			Weight Each (lb)
	1101 Galv.	1102 Galv.	1103 Galv.		Outside Dia. (A)	Rim Width (B)	Bore Size (C)	
3	900010	900216	900412	3/8	1-3/4	1/2	3/8	.25
4	900038	900234	900430	1/2	2-1/4	5/8	3/8	.75
5	900056	900252	900458	5/8	3	3/4	3/8	.50
6	900074	900270	900476	3/4	3-1/2	1	1/2	1.00
7	900092	900298	900494	7/8	4-1/4	1	1/2	1.25
8	900118	900314	900519	1	4-3/4	1-1/8	5/8	1.75

FOR REGULAR MANILA ROPE BLOCKS – NEW STYLE

Block Size	Stock No.	Manila Rope Size (in)	Sheave Size (in)			Sleeve Diameter (in)		Weight Each (lb)
	Bronze Bushed		Outside Dia.	Rim Width	Bearing Diam. (C)	I.D. (F)	O.D. (E)	
4	2028373	1/2	2-1/4	5/8	5/8	3/8	5/8	.75
6	2028375	3/4	3-1/2	1	3/4	1/2	3/4	1.00
8	2028376	1	4-3/4	1-1/8	7/8	5/8	7/8	1.75

FOR MANILA ROPE SNATCH BLOCKS – OLD STYLE

Block Size	Stock No.			Manila Rope Size (in)	Sheave Size (in)			Sleeve Diameter (in)		Weight Each (lb)
	1141 Galv.	1142 Galv.	1143 Galv.		Outside Dia.	Rim Width	Bearing Diam. (C)	I.D. (F)	O.D. (E)	
6	902018	902214	902410	3/4	3	1-1/8	3/4	1/2	3/4	1.00
7	902036	902232	902438	7/8	3-1/2	1-1/4	3/4	1/2	3/4	2.00
8	902054	902250	902456	1	4-1/2	1-3/8	7/8	5/8	7/8	3.00
10	902072	902278	902474	1-1/4	5-3/4	1-7/8	1	3/4	1	7.00
12	902090	902296	902492	1-1/2	6-3/4	2-1/8	1	3/4	1	12.0

FOR MANILA ROPE SNATCH BLOCKS – NEW STYLE

Block Size	Stock No.			Manila Rope Size (in)	Sheave Size (in)			Sleeve Diameter (in)		Weight Each (lb)
	Bronze Bushed Red	Bronze Bushed Galv.			Outside Dia.	Rim Width	Bearing Diam. (C)	I.D. (F)	O.D. (E)	
6	2027020	2027021		3/4	3	7/8	3/4	-	-	1.30
8	2028971	2027015		1	4-1/8	1-3/8	1	-	-	3.74
10	2028972	2026507		1-1/4	6	1-5/8	1-1/2	-	-	10.00
12	2028973	2026509		1-1/2	8	1-5/8	1-1/2	-	-	12.00

FOR MANILA AND WIRE ROPE SNATCH BLOCKS – OLD STYLE

- 1298 - Bronzed Brushed, Self-Lubricating Steel sheave for Wire Rope.
- 1192 - Bronzed Brushed, Self-Lubricating Iron sheave for Wire Rope.
- 1293 - Bronzed Brushed, Self-Lubricating Steel sheave for Manila Rope.

Snatch Block		Stock No.			1192 Wire Line Size	1293 Painted Stock No.	1293 Manila Rope Size	Sheave Size (in)				Bushing I.D.	Sleeve Dimensions (in)			Weight Each (lb)		
Style	Shell Length	1298 Painted	1192 Painted	Outside Dia.				Hub Width	Rim Width	Bore Size	I.D.		O.D.	Length	1298	1192	1293	
924	-	922005	-	5/8	-	-	6	1-3/8	1-1/4	1-5/8	1-1/4	1	1-1/4	1-1/2	6.00	-	-	
924	-	922023	-	3/4	-	-	8	1-5/8	1-1/2	1-7/8	1-1/2	1-1/4	1-1/2	1-3/4	11.0	-	-	
924	-	922041	-	7/8	-	-	10	1-5/8	1-1/4	2-1/2	2	1-1/2	2	1-3/4	19.0	-	-	
924	-	922069	-	7/8	-	-	12	2	1-3/4	2-1/2	2	1-1/2	2	2-1/8	22.0	-	-	
940-941	-	922078	920579	3/8	-	-	4	13/16	3/4	1-1/8	3/4	1/2	3/4	7/8	3.00	2.00	-	
940-941	-	922087	920588	1/2	-	-	6	1-1/16	1	1-3/8	1	3/4	1	1-1/8	7.00	3.84	-	
940-941	-	922103	920604	5/8	-	-	8	1-3/8	1-1/4	1-1/2	1-1/8	7/8	1-1/8	1-1/2	8.00	9.90	-	
940-941	-	922121	920622	5/8	-	-	10	1-3/8	1-1/4	1-5/8	1-1/4	1	1-1/4	1-1/2	12.0	17.0	-	
940-941	-	922149	920640	3/4	-	-	12	1-5/8	1-1/2	1-7/8	1-1/2	1-1/4	1-1/2	1-3/4	39.0	32.0	-	
1096	6	-	-	-	921505	7/8	3	1-3/16	1-1/8	1-3/8	1	5/8	1-1/4	1-1/2	-	-	2.00	
1096	8	-	-	-	921523	1	4-1/2	1-7/16	1-3/8	1-5/8	1-1/4	7/8	1-1/4	1-1/2	-	-	6.00	
961	-	922407	-	5/8	-	-	6	1-5/8	1-1/2	2	1-5/8	1-1/4	1-5/8	1-3/4	9.00	-	-	
961	-	922425	-	7/8	-	-	8	1-11/16	1-1/2	2-1/2	2	-	-	-	15.0	-	-	

Sheaves highlighted above in bold italic are available with reduced lead times due to our advanced manufacturing process.